

N

HARMONY MAKER COLLECTION



NATUZZI
ITALIA

LETTER FROM THE CEO

When people ask me what the secret is behind our exciting story, my response is always the same:

Love for our work. For many years, this has been the thread that runs through past and present, and values that have never changed: unconditional love for our family and our roots, honesty towards our customers, a sense of responsibility to those who work with us, and respect for the environment in which we all live. We put heartfelt passion into what we do, striving for perfection, beauty and harmony, inside and out. As though it were still the very first day. And we work with the strong conviction that doing business means, above all, a commitment to shared growth and providing an example for our children, our region and our country. Love for our work: this is what has made us into the best furniture craftsmen in the world.

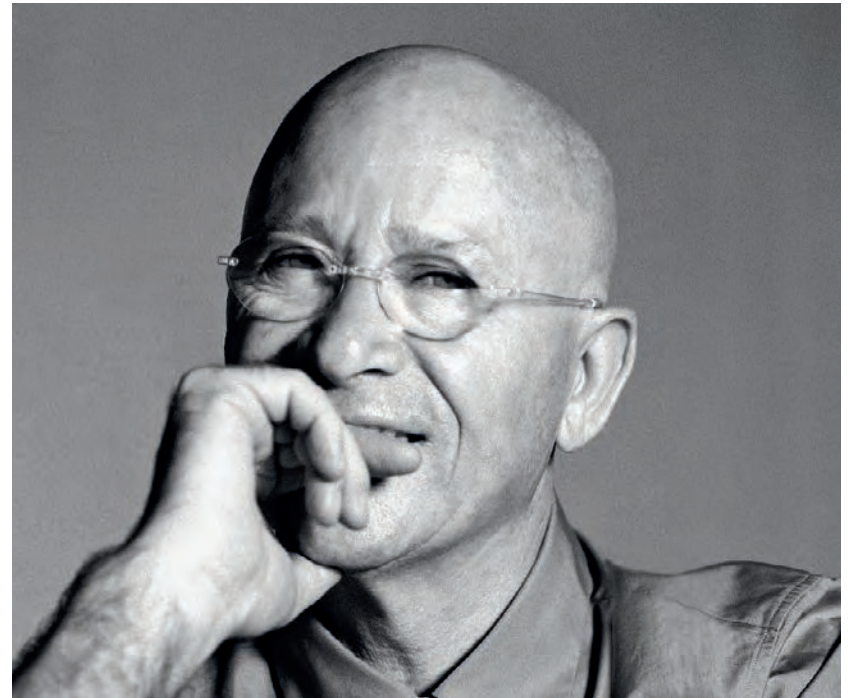

Paquale Notuzzi





CONTENTS.	THE HISTORY	4
	HARMONY MAKER	6
	QUALITY	9
	ECO-SUSTAINABILITY	11
	INNOVATION	12
	LIVING	15
	RE-VIVE	154
	DINING	163
	BED	185
	MATERIALS	212
	LEATHERS	214
	FABRICS	217
	PADDING	219
	WOOD	220
	TECHNICAL	223
	SPECIFICATIONS	
	IN THE WORLD	292

NATUZZI.

An Italian story since 1959.



Pasquale Natuzzi opens his first workshop in Puglia. The first sofas are made here, entirely by hand.

The workshop is transformed into a model of Italian excellence. We are joined by new collaborators, new craftsmen. And we create new collections.



The Natuzzi style is born: sofas in coloured leather, designed to offer complete and unparalleled comfort. From our roots in Puglia, our innovation conquers the USA.

The company is listed on the New York Stock Exchange. The collections are enhanced with furniture, furnishings and accessories: the Natuzzi lifestyle is born.



1990s



2000

New stores are opened in New York, Dubai, New Delhi, Peking, Sao Paolo, Sydney and London. We enter into partnerships with internationally renowned designers.

Natuzzi is one of the best known names in the world of international furniture design. In 2013 and 2015, we had the highest brand awareness of all our leading competitors*. Our distribution network has retail stores in Italy, Europe, USA, China, Taiwan, Russia, India, United Arab Emirates, Australia and Mexico.

**Source: Lagardère - IPSOS*



Today

“ It all began almost 60 years ago. Our small workshop became a big company that now exports all over the world. ”

HARMONY MAKER.

We combine research, creativity, skilled craftsmanship and technology in a process that has been perfected through years and years of work.

Only through this, can harmony take shape in our hands.

TREND STUDY

The analysis of emerging lifestyles and international fashion, art and furniture trends forms the initial phase of our projects, which are continuously adapted to suit current living trends.

STYLE CENTRE

In our Italian Style Centre, our designers, colourists and interior decorators work on the design of each individual model, the different settings and the fusion of design, function, materials and colours.

PROTOTYPE

Expert craftsmen transform our ideas into reality. Expert hands work polyurethane, cut leather, and stitch fabrics. And so, the prototype is born: an indispensable step to improve and further enhance the design.

ENGINEERING

Initial production begins in our experimental lab, a shining example of innovation and technology. Here the industrial methods are optimised, all in compliance with the strictest quality standards.

CRAFTSMANSHIP

In our Italian factories, a unique combination of human knowledge and cutting-edge technology is achieved: a priceless company asset.

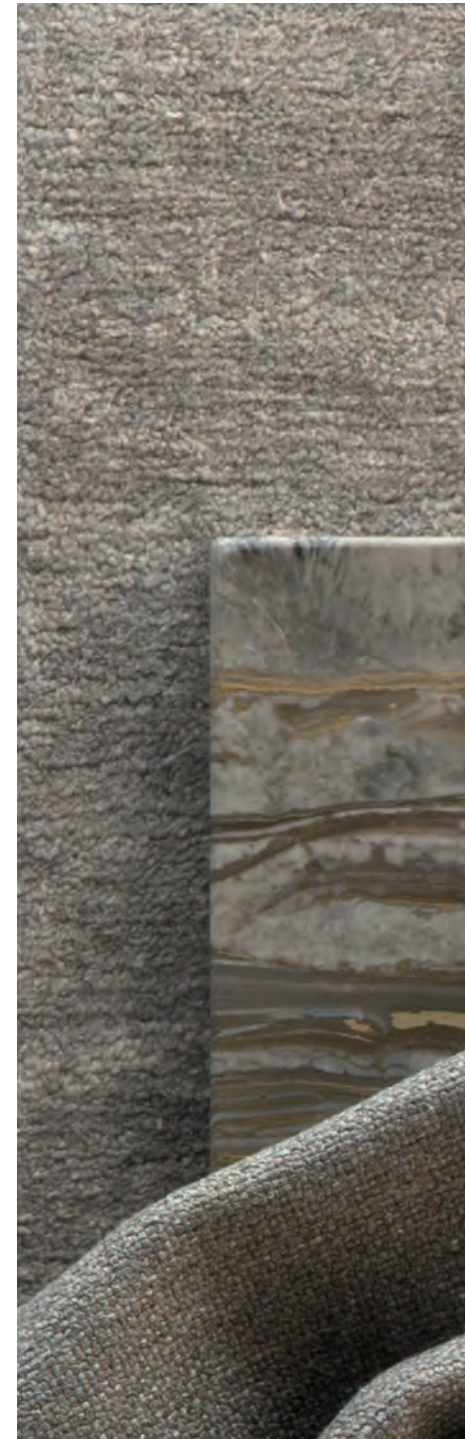







QUALITY.

The direct control of our production and raw materials gives life to high quality Italian creations, certified by the most prestigious international institutions.

92%

This is the percentage of raw materials that we control directly. It is also a promise of quality, because all our materials are rigorously tested, toxic-free and produced in compliance with the law.

QUALITY CONTROL

Our creations are designed to last. We are able to achieve this because each sofa, armchair, cabinet or bed is subjected to countless tests to check the load, stability and the product's resistance to wear, friction, damage and light.

THIS IS AUTHENTIC ITALIAN PRODUCTION.

Each phase of the production process takes place in our factories in Italy. The design, leather tanning, padding production: our 100% Italian craftsmanship is guaranteed right down to the very last stitch.

INTERNATIONAL CERTIFICATIONS

The value of our choices is proven by the international certificates ISO 14001, ISO 9001 and OHSAS 18001, relating to quality management and environmental responsibility.





ECO-SUSTAINABILITY.

Respect for the environment is the first step to safeguarding our health. It is an act of social responsibility and is reflected in everything we do.

LEATHER

The selection and tanning of our leather takes place in our Italian tannery, in accordance with current environmental legislation which is among the most restrictive in the world.

WOOD

We only use wood sourced from renewable forests. Furthermore, all wood-based materials are produced in accordance with the laws governing formaldehyde content, to ensure our products are completely toxic-free.

PADDING

All the polyurethanes used in our padding are produced completely free from Freon and other harmful chemicals.

HEALTH

Our sofas, furniture and accessories are produced and packaged without the use of harmful substances.

CLEAN AND RENEWABLE ENERGY

There are five active solar panel systems at our Headquarters at Santeramo in Colle and our factories, fulfilling a significant proportion of our energy needs.

INNOVATION.

The desire to push ourselves and imagine things that have never been done before has always been an important characteristic of our history. This is why innovation is one of the most important traditions of Natuzzi Italia.

INNOVATION SINCE DAY ONE

The Natuzzi story is one of research and development; from the beginning, we have intuitively identified the desires and needs of our customers. Our work has been driven by innovation since 1959, through experimentation with new technologies, new materials and new features.

SUCCESS OVER TIME

The Natuzzi history has been characterised by successful innovations that have changed the world of furniture forever. Some examples are: the coloured leathers of the 1980s, the recliner mechanisms of the 1990s, or the latest generation motion sofas of the new millennium.

TODAY'S ICONS

Today, the icon of our innovation is Re-vive. Re-vive is an interpretation of the perfect union of ergonomic comfort, cutting-edge technology and functional design: a heritage of knowledge that reverberates throughout our collection and in every single one of our creations.



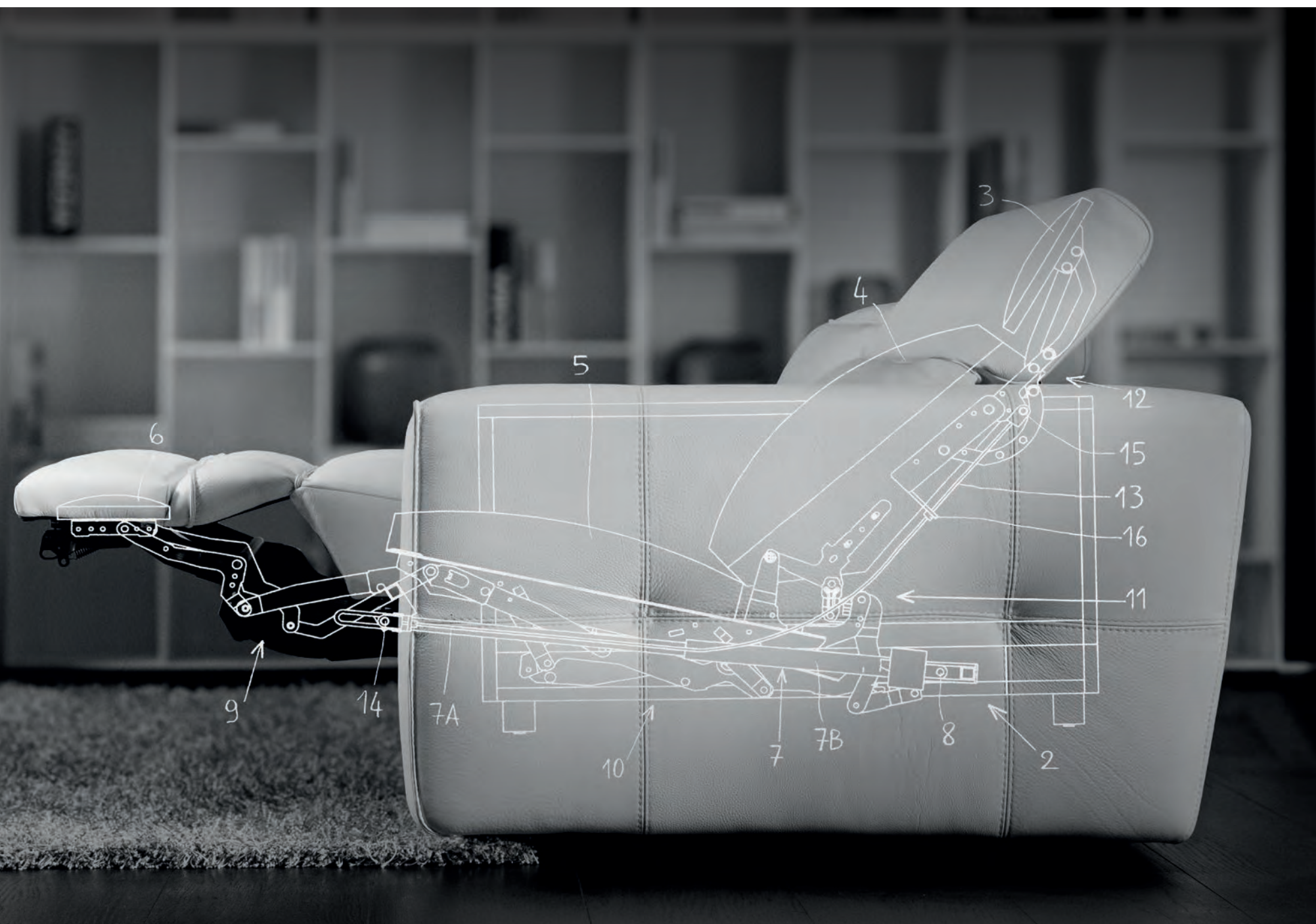



A close-up photograph of dark green leather upholstery, likely from a sofa or chair. The leather is tufted, creating a series of rounded, overlapping sections. The lighting is dramatic, highlighting the texture and sheen of the material. The word "Living" is written in a white, elegant serif font across the middle-right portion of the image.

Living

1. LA SCALA SOFA available in 106 colours of leather and in 122 colours of fabric.
A "Chesterfield" sofa with a new form for the armrest and frame. | 2. MARCUS RUG hand-tufted
on a loom. | 3. Ginger and Grace side tables by Paola Navone with mirrored glass top.
| 4. NESSA LAMP in blown glass.



1.

3.

2.

Design **CLAUDIO BELLINI**

LA SCALA

*A classic, designed according to the best
Italian craftsmanship tradition.*



4.





The mix of padding that combines expanded polyurethane, memory foam and Climalight (a special silicone-treated microfibre) guarantees extraordinary comfort, offering support and lasting good looks. The exquisite hand-quilting is an expression of true craftsmanship of the highest order. The leather or fabric buttons are hand-stitched and match the upholstery.



Design MANZONI & TAPINASSI

HERMAN

*A collection of complete, harmonious
and extremely modular furniture.*









1. HERMAN SOFA modular, available in 122 colours of fabric and 106 colours of leather. The exceptional range of modular possibilities enables the same elements to be reused time and again, changing the position or using them as standalone pieces. In the photo, two-seater with chaise longue in leather and in fabric. The hand-stitched quilting is an expression of craftsmanship of the highest order, and highlights the softness of the seat and the backrest for unparalleled visual comfort. | **2.** PROXIMA BOOKCASE free-standing with an oak structure and shelves in tempered glass. | **3.** Sofa complemented by the unique metal structure that encloses the seats. | **4.** HERMAN OTTOMAN with a metal structure and upholstery in fabric or leather. | **5.** HERMAN COFFEE TABLE with a Calacatta Oro marble top and a metal structure which reflects the design and supporting structure of the sofa. | **6.** GONG LAMP in metal and blown glass. | **7.** AFFRESCO RUG hand-woven with wool pile, salt-washed for a vintage effect.

HERMAN SOFA modular section, in fabric. The individual elements of the Herman sofa are available in 122 colours of fabric and 106 colours of leather.







- 1. HERMAN SOFA available in different linear and corner compositions. | 2. Detailed view of the metal structure enclosing the seats, available in two finishes. | 3. HERMAN OTTOMAN with a metal structure and upholstery in fabric or leather. | 4. HERMAN SIDE TABLE available with a metal structure and etched glass or oak top. | 5. SETI RUG in hand-knotted bamboo silk.

2.





1.

5.

4.

3.



1. The mix of padding that combines expanded polyurethane, memory foam and Climalight (a special silicone-treated microfibre) guarantees extraordinary comfort, offering support and lasting good looks. In the photo, modular element in fabric, also available in leather. | **2.** Cushion with internal movement-activated adjustment mechanism. | **3.** HERMAN COFFEE TABLE available with a Orobic marble top and metal structure which reflects the design and supporting structure of the sofa. | **4.** HERMAN COFFEE TABLE available with a metal structure and etched glass or oak top. | **5.** VICO TABLE LAMP by Victor Vasilev with a metal structure and lampshade.

LONG BEACH SOFA leather modular sofa available in various linear and corner compositions with and without chaise longue, in 106 colours of leather and 122 colours of fabric. Thanks to the supreme modular versatility, the individual elements can be rearranged or used as standalone pieces. The individual elements are available in fabric and leather. In the photo, three-seater sofa in leather.



Design **CLAUDIO BELLINI**

LONG BEACH

*A system of modular seats,
a fusion of exquisite materials and Italian workmanship.*





1.

1. KUBIKA MODULAR WALL by Pierangelo Sciuto, wall unit system composed of modular elements, open cabinets and door cabinets available in different sizes to be arranged and combined in a customizable style.



4.

2. LONG BEACH SOFA two-seater sofa in fabric. | 3. LONG BEACH COFFEE TABLE with a metal structure and wooden top. | 4. KUBIKA END UNIT in wood and lacquer with open cabinet. Also available with a drawer. | 5. RHOMBUS RUG in vegetable silk.

LONG BEACH with backrest in goose feathers, enhanced with an embossed profile to underline the refined artisan style of the model. The mix of polyurethane, memory foam and feather padding guarantees extraordinary comfort, offering support and lasting good looks.





2.

1.

1. IDO SOFA available in 122 colours of fabric and 106 colours of leather.
| 2. PLISSÉ BOOKCASE by Victor Vasilev with a matt lacquer anthracite structure and shelves .

Design MAURO LIPPARINI

IDO

*Seating system combined
with table surfaces and furnishing accessories.*



Mauro Lipparini.

An eclectic architect and designer, Mauro Lipparini expresses his creativity in every field: complex industrial projects, interior architecture, installations and project studies. He is one of the leading exponents of the world-renowned "Italian minimalism" and has gained numerous accolades confirming his talent. Having graduated in Florence in 1980, he chose Italy as the ideal base for his research and work.

DESIGNER.



3.

1.

2.

4.

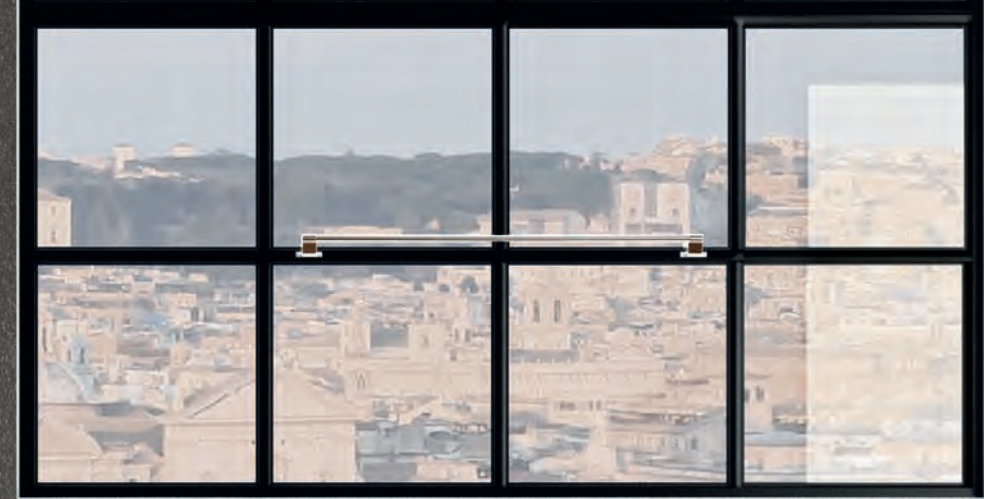

- 1. IDO SOFA in fabric. The feather lumbar cushions improve the comfort of the seat.
- | 2. IDO COFFEE TABLE with a metal structure and matt lacquer top. | 3. VICO TABLE LAMP by Victor Vasilev with a metal structure and lampshade.
- | 4. MARCUS RUG hand-tufted.



1. IDO SOFA modular element with surfaces in various wood finishes, available in leather and in fabric. | **2.** PLISSÉ BOOKCASE by Victor Vasilev with a free-standing structure in fiddleback briar-root and lacquered shelves.





1.

3.

2.

1. IDO SOFA modular element with central and end table units available in various wooden finishings. Pictured, modular element in leather with end unit.
| 2. AFFRESCO RUG hand-woven wool pile, salt-washed for a vintage effect.
| 3. IDO COFFEE TABLE with a metal structure and top.

1. JEREMY SOFA corner version, available in 122 colours of fabric and 106 colours of leather. Support and lasting looks are guaranteed by the mix of polyurethane, memory foam and feather padding. | 2. TEMPO COFFEE TABLE by Manzoni & Tapinassi with metal structure and nickel silver top. | 3. PITAGORA RUG in hand-knotted wool.

1.

2.

3.



Design MANZONI & TAPINASSI

JEREMY

*Right-angled lines, exceptional comfort.
A jigsaw of armrests and frames.*



4.

7.

1.

2.

5.



1. JEREMY SOFA available in leather and fabric. | 2. IDO TABLE by Mauro Lipparini with a metal structure and lacquer top. | 3. IDO SIDE TABLE with lacquer top or Silver Wave marble top. | 4. MARTINI FLOOR LAMP in soft-touch finished metal. | 5. AFFRESCO RUG hand-woven wool pile, salt-washed for a vintage effect. | 6. VICO LAMP by Victor Vasilev with a metal stand. | 7. NOVECENTO BOOKCASE in oak. The wall unit system is characterised by modular elements enabling the creation of personalised combinations.

6.

3.

2.

Design MANZONI & TAPINASSI

DORIAN

*Timeless beauty, extreme modular versatility:
A Natuzzi collection evergreen.*

1.

3.

4.

5.

1. DORIAN SOFA modular, available in 106 colours of leather and 122 colours of fabric. Pictured, modular element in leather leather and in fabric. | 2. MARTINI LAMP in etched metal. | 3. MARCUS RUG hand woven. | 4./5. TEMPO COFFEE TABLE by Manzoni & Tapinassi available with a metal base and satin glass top or a nickel silver top. | 6. HEX TABLE fixed with a solid wood structure and top in extra-clear or tinted tempered glass. | 7. HEDI CHAIR upholstered in leather. Also available in fabric. | 8. KUBIKA MODULAR WALL, wall unit system composed of modular elements, open cabinets and door cabinets available in different sizes which can be combined in a personalised way. Available in various lacquer finishings and colours.





1. DORIAN SOFA corner version available in leather and fabric. The individual elements are available in fabric and leather. In the photo, corner sofa in leather and in fabric. Support and lasting looks are guaranteed by the mix of polyurethane, memory foam and feather padding, offering extraordinary comfort. | **2.** PITAGORA RUG in hand-knotted wool. | **3.** FORTUNA SIDEBOARD by Claudio Bellini with a solid wood structure, top in satin glass and interior in matt lacquer.





3.



1.

1. CHOCOLAT COFFEE TABLE with a metal structure and an Imperial Grey marble top.
| 2. DORIAN is also available with raw-cut stitching when upholstered in exquisite thickened Cassidy leather or the innovative Manopesca fabric.
Thanks to the supreme modular versatility, the individual elements can be rearranged or used as standalone pieces.

2.



1. POLIZIANO SOFA available in 122 colours of fabric and 106 colours of leather. Also available in the two-seater version. The mix of polyurethane, memory foam and feather padding guarantees extraordinary comfort. The loose feather cushions are available in various shapes, sizes, colours and upholsteries. The solid wood base with metal inserts brings a modern twist to a timeless classic. | 2. VIAGGIO ARMCHAIR in leather with metal armrests. | 3. IDO COFFEE TABLE by Mauro Lipparini with a metal structure and anthracite lacquer top. | 4. IDO SIDE TABLE by Mauro Lipparini with a metal structure and Silver Wave marble top. | 5. PITAGORA RUG in hand-knotted wool. | 6. ONDA FLOOR LAMP with metal stand and lampshade cast from a single mould.

2.

6.

3.

5.

Design MANZONI & TAPINASSI

POLIZIANO

*Classic lines and exquisite materials pay
homage to the Renaissance artist.*

1.

4.



2.

4.

5.

Design **CLAUDIO BELLINI**

DON GIOVANNI

*Undulating forms, the seduction of comfort
and all the values of the Italian spirit.*

1.

6.

3.

1. DON GIOVANNI SOFA available in 122 colours of fabric and 106 colour of leather, also available in a two-seater version. | 2. LEYRA ARMCHAIR in fabric, also available in leather. | 3./4. TEMPO COFFEE TABLE by Manzoni & Tapinassi with a metal base and Calacatta Oro marble or wood top. | 5. PITAGORA RUG in hand-knotted wool. | 6. VICO TABLE LAMP by Victor Vasilev with a metal structure.



Manzoni & Tapinassi.

In 2001, the expressive originality of Architect Maurizio Manzoni and the notable experience of Professor Roberto Tapinassi came together to form one of the most significant professional partnerships in Italy. From the beginning, the two designers have shared a common vision of contemporary living, developing innovative solutions in line with Italian tradition with a focus on cutting-edge innovation and research.

1/2. SVEVO SOFA available in 122 colours of fabric and 106 colours of leather. Support and lasting good looks are guaranteed by the mix of polyurethane, memory foam and feather padding, offering extraordinary comfort.

| 3. AFFRESCO RUG hand-woven wool pile, salt-washed for a vintage effect.

| 4. ELSA FLOOR LAMP with a metal stand and lampshade.



1.

3.

DESIGNER.

Design MANZONI & TAPINASSI

SVEVO

*A 1950s-inspired furniture collection
characterised by elegant lines.*

2.

4.





2.



3.



1.

1. SVEVO SOFA Armrests and feet in solid wood with an oak or walnut veneer with metal inserts available in various finishes. | **2./3.** SVEVO COFFEE TABLE with feet and top in solid walnut or top in Calacatta Oro marble.

Design MANZONI & TAPINASSI

GIO

*Italian design, elegant comfort
and perfect proportions.*



1.



2.





1. GIÒ SOFA available in 106 colours of leather and 122 colours of fabric, in the two-seater, three-seater and large three-seater version. The solid wood base and feet bring a touch of originality to the model. | 2. SVEVO COFFEE TABLE by Manzoni & Tapinassi with solid walnut feet and a Calacatta Oro marble top. | 3. AFFRESCO RUG beige, hand-woven wool pile, salt-washed for a vintage effect. | 4. SVEVO SIDE TABLE by Manzoni & Tapinassi with feet in solid walnut and an olive walnut top.



1.



1. GIÒ SOFA three-seater in leather. The mix of polyurethane, feathers and memory foam padding guarantees extraordinary comfort, offering support and lasting good looks. | 2. ACCADEMIA BUFFET CABINET by Bernhardt & Vella with an olive walnut wood structure and lacquered visible interior. Available with open cabinets and door cabinets with hinged doors.

Design NATUZZI DESIGN CENTRE

IAGO

*A theatrical name
for a visually striking sofa.*

1.



1. IAGO SOFA available in 122 colours of fabric and 106 colours of leather, with additional linear and corner compositions, with or without recline function. The mix of polyurethane and memory foam padding guarantees extraordinary comfort, offering support and lasting good looks. | **2.** IDO SIDEBOARD by Mauro Lipparini, system of sideboards with open cabinets and drop-down doors. Metal structure and wooden door cabinet. | **3.** SETI RUG in hand-knotted bamboo silk.



1. TEMPO COFFEE TABLE by Manzoni & Tapinassi with metal base and wood top in smoked oak or metal top in nickel silver. | 2. The space-saving Zerowall system activates the recline function without the need to position the sofa away from the back wall.



3. IAGO SOFA three-seater with individually activated electric recliner mechanisms for each seat, thanks to the Soft Touch mechanism, also available with rechargeable batteries to avoid unsightly cables.



Watch the video.





1.

4.

2.

1./2. PHILO SOFA available in 122 colours of fabric and 106 colours of leather, also available in alternative linear and corner compositions, with or without recline function. | 3./4. LABIRINTO TABLE by Claudio Bellini in tinted glass and rotatable bookcase in mirrored glass.

Design NATUZZI DESIGN CENTRE

PHILO

*An iconic sofa distinguished
by skilfully worked quilting.*



3.



1.

3.

1. PHILO SOFA with 2 optional recline functions activated by Soft Touch buttons.
All Philo elements are also available with a manually adjustable headrest.



2. VIAGGIO ARMCHAIR with a wooden structure and metal armrests, in fabric and in leather.
| 3. SETI RUG in hand-knotted bamboo silk.



Watch the video.



2.

1.

3.

Design MANZONI & TAPINASSI

FIDELIO

Inspired by the theatre, paying homage to a synthesis of design, comfort and function.

1. FIDELIO SOFA available in 106 colours of leather. The mix of expanded polyurethane and memory foam padding guarantees excellent comfort, durability and lasting good looks.
2. ANTEPRIMA ARMCHAIR by Claudio Bellini, available in 122 colours of fabric and 106 colours of leather.
3. SETI RUG in hand-knotted bamboo silk.



1.



1. FIDELIO SOFA also available with optional electric recliner mechanisms, activated separately for each individual seat. The Zerowall space-saving system eliminates the need to move the sofa away from the wall when the Soft Touch mechanism simultaneously opens the seat, headrest and footrest. Also available with rechargeable batteries to avoid unsightly cables.
2. CABARET COFFEE TABLE with metal structure and glass top. | 3. Close-up of the Fidelio sofa armrest with Soft Touch mechanism.

Watch the video.





2.

Design NATUZZI DESIGN CENTRE

SURROUND

*Exquisite finishes and a built-in audio system:
comfort transformed into a multi-sensory experience.*



1.

3.

1. SURROUND SOFA corner version, available in 106 colours of leather, also available in three-seater and two-seater versions. | 2. HERMAN COFFEE TABLE with a metal structure and top in etched glass. | 3. AFFRESCO RUG hand-woven in wool pile, salt-washed for a vintage effect.



Natuzzi Design Centre.

A team of architects, interior designers, colourists work to develop individual models, different settings and combinations of design, function, materials and colours.

DESIGNER.



- 1.** The audio system is an optional feature activated by Bluetooth, USB, AUX and Apple iOS. The audio speakers are built in to the sofa structure.
- | **2.** Adjustable headrest and built-in audio system.
- | **3.** Cushion included in the modular version to enable the corner element to be used as a seat.



Watch the video.

3.

1. AGORÀ SOFA modular, available in 122 colours of fabric and 106 colours of leather. Thanks to the supreme modular versatility, the individual elements can be rearranged or used as standalone pieces. The individual elements are available in fabric and leather. In the photo, the three-seater version upholstered in removable fabric and in leather. | 2. IDO COFFEE TABLE by Mauro Lipparini with a varnished metal structure and a top in aged walnut. | 3. VICO LAMP by Victor Vasilev with a metal structure.



Design MANZONI & TAPINASSI

AGORÀ

*A timeless sofa
that adapts to any setting.*





6.

2.

1.

5.

7.



1. AGORÀ SOFA corner version in leather also available in fabric. The grosgrain piping enhances the model and emphasises the welcoming shapes. The mix of polyurethane, feathers and memory foam padding guarantees extraordinary comfort, offering support and lasting good looks. | **2.** PROXIMA BOOKCASE free-standing with an oak structure and shelves in bronze glass. | **3.** IDO TABLE by Mauro Lipparini with a metal structure and top. | **4./5.** IDO SIDE TABLE by Mauro Lipparini with top in Silver Wave marble and metal. | **6.** AURA ARMCHAIR by Claudio Bellini in velvet, also available in leather. | **7.** AFFRESCO RUG hand-woven wool pile, salt-washed for a vintage effect.



1. TEMPO SOFA two-seater with chaise longue available in 122 colours of fabric and 106 colours of leather. The mix of polyurethane, memory foam and feather padding guarantees extraordinary comfort, offering support and lasting good looks. | 2. TEMPO COFFEE TABLE with an anthracite metal base and steel top in a nickel silver finish.

Design MANZONI & TAPINASSI

TEMPO

*Time stands still in the embrace
of a design that will delight for an eternity.*

1.





1.



1. CABARET BEHIND-SOFA CONSOLE TABLE in metal with wooden shelves. | **2.** PLISSÉ BOOKCASE by Victor Vasilev with a free-standing aged walnut veneered structure with shelves in matt lacquer. | **3.** TEMPO ARMCHAIR in fabric and in leather. | **4.** PITAGORA RUG in hand-knotted wool.



4.

5.

3.

2.



1. TEMPO SOFA modular, available in 122 colours of fabric and 106 colours of leather. | 2./3./4. TEMPO COFFEE TABLE with an anthracite metal structure and a steel top in a nickel silver finish and with a coffee satin glass or smoked oak top. | 5. AFFRESCO RUG hand-woven with wool pile, salt-washed for a vintage effect.



1.

2.

1. TREVI SOFA corner version, available in 122 colours of fabric and 106 colours of leather, also available in three-seater or two-seater versions. The sofa features a solid wood and metal base. The loose cushions are filled with feathers and are available in various shapes, sizes, colours and upholsteries. | 2. CABARET COFFEE TABLE with a metal structure and tempered glass top. | 3. AFFRESCO RUG hand-woven wool pile, salt-washed for a vintage effect.

Design MANZONI & TAPINASSI

TREVI

*A timeless sofa
that adapts to any setting.*



1. FORMA SOFA modular, available in 122 colours of fabric and 106 colours of leather. Thanks to the supreme modular versatility, the individual elements can be rearranged or used as standalone pieces. The individual elements are available in fabric and leather. | 2. CABARET COFFEE TABLE with a metal structure and Carrara marble top.



Design **CLAUDIO BELLINI**

FORMA

A archetypal classic transformed into a modular sofa designed for urban settings.





1. FORMA SOFA modular corner element, also available in linear and corner compositions, with and without chaise longue. In the photo, corner element in fabric and in leather. | 2. CAMMEO ARMCHAIR in leather, with a metal structure and rear of the backrest upholstered in leather. Also available in fabric. | 3./4. CABARET SIDE TABLE with a metal structure and top in sanded and brushed Carrara marble.

5.

1.

3.

6.

2.



7.



4.

5. ONDA LAMP with a metal structure and lampshade, with a soft-touch finish. | 6. PITAGORA RUG in hand-knotted wool. | 7. The trim, also available in contrasting colours, emphasises the geometric shapes and the skilled craftsmanship of the model.

1. TENORE SOFA

available in 106 colours of leather, in 122 colours of fabric, in a leather/fabric mix and in alternative linear arrangements with or without chaise longue. The mix of polyurethane and memory foam padding guarantees extraordinary comfort, offering support and lasting good looks. Metal feet in a geometric and tapered design. Skilled “moccasin” stitching also available in contrasting colours, which highlights the unique geometry of the armrest. | 2. IDO COFFEE TABLE by Mauro Lipparini with a metal structure and a top in smoked oak. | 3. MARCUS RUG hand-woven. | 4. PLISSÉ BOOKCASE by Victor Vasilev with a free-standing structure in aged walnut and lacquered shelves.



1.

3.



4.

2.

Design MANZONI & TAPINASSI

TENOIRE

*A precious sofa, a design
that resonates in every setting.*

Design **MANZONI & TAPINASSI**

TRATTO

*All of a sudden, soft lines outline
compact and exquisite comfort.*





3.

4.

6.

1. TRATTO SOFA available in 106 colours of leather and in 122 colours of fabric. | 2. TRATTO ARMCHAIR available in fabric, and leather. | 3. MARTINI FLOOR LAMP with a varnished metal structure and soft-touch finish. | 4. CABARET COFFEE TABLE with a metal structure and top in satin glass. | 5. CABARET SIDE TABLE with a top in satin glass. | 6. OTTAVIO RUG hand-woven.

Design NATUZZI DESIGN CENTRE

GOLF

Rounded lines and gleaming metals offer an experience of deep relaxation.

1.



2.



3.



5.



1./2. GOLF SOFA available in 106 colours of leather and 122 colours of fabric, also available in the corner, two-seater and armchair versions. | 3./4. CABARET COFFEE TABLES with a metal structure and Carrara marble or wood top. | 5. MUNEGA TABLE LAMP in blown glass. | 6. PITAGORA RUG in hand-knotted wool.

1. AVANA SOFA available in 106 colours of leather, in various linear or corner arrangements, with or without chaise longue. | 2. CAMMEO ARMCHAIR available in 106 colours of leather, with a metal structure and leather upholstery on the rear of the backrest. Also available in 122 colours of fabric. | 3. ACCADEMIA SIDEBOARD by Bernhardt & Vella in polished lacquer, composed of cabinets with hinged doors and open cabinets.

Design **NATUZZI DESIGN CENTRE**

AVANA

One of Natuzzi's best loved models for its functionality and versatility.





1.



1. Detail on the armrest tube and the side of the sofa which reflect the insert in the wooden feet. Stitching also available in contrasting colours.
| **2.** ONDA FLOOR LAMP with a metal structure and lampshade.
| **3.** CABARET COFFEE TABLE with a metal structure and stainless steel top in a nickel silver finish. | **4.** SETI RUG in hand-knotted bamboo silk.



2.

3.

4.

1. BORGHESE SOFA corner element with a wooden base, available in 106 colours of leather and in 122 colours of fabric. | 2. VIAGGIO ARMCHAIR with a wooden structure and metal armrests, in leather and in fabric. | 3./4./5. MERIDIO COFFEE TABLE with a metal tubular structure and wooden top, or lacquered top in the corner and side table versions. | 6. CUBE RUG hand-tufted.



2.

5.

4.



1.

3.

6.

Design NATUZZI DESIGN CENTRE
BORGHESE

*A testament to elegance,
refinement and skilled craftsmanship.*



1.



3.



1. BORGHESE SOFA with a metal base, available in 122 colours of fabric and 106 colours of leather. The mix of polyurethane and memory foam padding guarantees extraordinary comfort, offering support and lasting good looks. | **2.** IDO ROUND COFFEE TABLE with a metal structure and top. | **3.** IDO SIDE TABLE with a metal structure and Silver Wave marble top. | **4.** VICO TABLE LAMP by Victor Vasilev with a metal structure. | **5.** The headrest can be manually adjusted on each seat.



1. PRELUDIO SOFA corner version, available in 106 colours of leather and 122 colours of fabric, also available as a linear version and other corner arrangements. | 2./3. IDO TABLE by Mauro Lipparini, with a metal structure and oak top for the centre table version, or with a lacquered top in the side table version. | 4. VICO TABLE LAMP by Victor Vasilev with a metal structure. | 5. AFFRESCO RUG hand-woven wool pile, salt-washed for a vintage effect.



Design **NATUZZI DESIGN CENTRE**

PRELUDIO

*Horizontal shapes, a headrest on each seat:
this is the prelude to ultimate relaxation.*



1. PRELUDIO SOFA corner element in leather with adjustable headrest. The mix of polyurethane and memory foam padding guarantees extraordinary comfort, while offering support and lasting good looks. | **2./3.** The headrest and armrests are adjusted manually to fit the desired position. | **4.** PROXIMA BOOKCASE with a free-standing wooden structure and glass shelves.

4.



Design NATUZZI DESIGN CENTRE

QUADRO

Angular and compact lines bring modern and versatile comfort into the living area.

1.

3.

2.

4.



1. QUADRO SOFA corner version, available in 106 colours of leather and 122 colours of fabric, also available in linear and modular versions. The headrest can be manually adjusted on each seat | 2. CABARET COFFEE TABLE with a metal structure and satin glass top. | 3. CABARET SIDE TABLE with a metal structure and satin glass top. | 4. RIFLESSO RUG hand-knotted on a loom.



Design NATUZZI DESIGN CENTRE

DUCA

Audio technology combined with recline functions in a sofa of timeless prestige.





1.



2.

1. DUCA SOFA in leather with touch-operated Soft Touch recliner function for the seat, headrest and footrest. The Zerowall space-saving system avoids the need to position the sofa away from the back wall. | 2./3. Hidden door cabinet with mechanism to activate the audio system by USB, Bluetooth, AUX and Apple iOS. | 4. DUCA SOFA in 106 colours of leather and 122 colours of fabric. The mix of polyurethane and memory foam padding guarantees extraordinary comfort, offering support and lasting good looks. | 5./6. LABIRINTO TABLE by Claudio Bellini with a tinted mirrored glass top for the coffee table and side table. | 7. CABARET BEHIND-SOFA CONSOLE TABLE in metal with wooden shelves. | 8. RHOMBUS RUG in vegetable silk.



3.



4.

6.

5.

7.

8.

Watch the video.



Design NATUZZI DESIGN CENTRE

BRIO

*Musical inspiration evokes
vivacity and extreme versatility.*



1.

2.

3.



1./2. BRIO SOFA available in 122 colours of fabric and 106 colours of leather. In the photo, the two-seater version with chaise longue in fabric and in leather.
| 3./4. TEMPO COFFEE TABLE by Manzoni & Tapinassi with a metal structure and wood or etched glass top.
| 5. MARCUS RUG hand-woven.
| 6. KUBIKA MODULAR WALL by Pierangelo Sciuto with a structure in smoked oak and door cabinets with coffee-coloured lacquered doors and black chrome-effect metal. Available in various lacquer finishings and colours.



4.

5.

6.

1. Built-in speakers in the version with the Bluetooth-activated audio system.

| 2/3. BRIO SOFA with optional electric features, Soft Touch mechanism available for each seat: the touch-activated recline function adjusts the seat, backrest and footrest simultaneously. The space-saving Zerowall system activates the recline function without the need to position the sofa away from the back wall. | 4. OMEGA DESK by Manzoni & Tapinassi with a varnished metal structure and Calacatta Oro marble top. | 5. ROSE CHAIR padded and upholstered in leather, also available in fabric. | 6. ASTRA ABAT JOUR in opaline glass.





Watch the video.

Design NATUZZI DESIGN CENTRE

VOLO

*Lightness is the inspiration
behind this compact and
highly versatile model.*

1/2. VOLO SOFA available in 106 colours of leather and 122 colours of fabric, and in other corner compositions or as an armchair, with or without recline function. The mix of polyurethane and memory foam padding guarantees extraordinary comfort, offering support and lasting good looks. | **3.** PLATEA ARMCHAIR in fabric and in leather. | **4.** CABARET COFFEE TABLE with a metal structure and satin glass top. | **5.** ASTRA FLOOR LAMP with a painted steel structure. | **6.** VELIO RUG hand-knotted on a loom.





5.

2.

4.

6.



1. VOLO SOFA two-seater in leather with optional recline function. The Soft Touch mechanism activates the recline function to adjust the seat, backrest and footrest simultaneously. | 2. The space-saving Zerowall system activates the recline function without the need to position the sofa away from the back wall. | 3. The skilful stitching, also available in contrasting colours, demonstrates Natuzzi's long history of leatherwork. | 4. Adjustable headrest for each seat.



3.



4.



Design NATUZZI DESIGN CENTRE

DIESIS

A melodic name underlining the model's new and improved comfort and space optimisation.





1.

2.

5.

4.

3.



6.

1. DIESIS SOFA corner version available in 122 colours of fabric and 106 colours of leather. The optional recline function is activated by the soft-touch mechanism. The space-saving Zerowall system activates the recline function without the need to position the sofa away from the back wall. Also available as a sofa bed featuring an antibacterial and hypoallergenic polyurethane mattress, as well as in various linear and corner elements with and without chaise longue. | **2.** Adjustable headrest for each seat apart from the sofa corner seat. | **3.** BIS OTTOMAN in fabric, also available in leather and in other shapes and dimensions. | **4.** OTTAVIO RUG hand-woven. | **5.** ACCENT MERIDIO SIDE TABLES with a metal tube structure and lacquered top. | **6.** The skilful stitching, also available in contrasting colours, runs along the sofa's outer edge to emphasise the shape.



Watch the video.

Design NATUZZI DESIGN CENTRE

NOTTURNO

*Generous comfort and contemporary shapes
offer a well-deserved rest.*





NOTTURNO SOFA corner version with bed function, also available as a linear version, with single beds. Sprung or polyurethane mattress with antibacterial and hypoallergenic treatment. The ready-bed feature activates the bed function in a single movement.

1. NOTTURNO SOFA corner version, available in 122 colours of fabric and 106 colours of leather, also available in three-seater and two-seater versions, with or without chaise longue.

| 2. TABLÒ COFFEE TABLE with an oak structure. | 3. Manually adjustable headrest on each seat.

| 4. ASTRA FLOOR LAMP with a steel structure and opaline glass lampshade.

| 5. NOVECENTO BOOKCASE in oak. The wall unit system is characterised by modular elements enabling the creation of personalised combinations.



Watch the video.



Design NATUZZI DESIGN CENTRE

AMADEUS

Assertive and masculine lines bring a new personality to every setting.

1.



2.



4.



3.

Side page **1**. AMADEUS ARMCHAIR in leather with wooden feet available in different finishes and enhanced by a thin metal plate. The trim which outlines the outer edge of the armchair, also available in contrasting colours, emphasises the shape and characterises the design. The mix of expanded polyurethane and feather padding guarantees exceptional comfort. The armchair is complemented by the footrest and is available in 106 colours of leather. | **2**. SVEVO COFFEE TABLE by Manzoni & Tapinassi with solid stained smoked oak feet and a Calacatta marble top. | **3**. AFFRESCO RUG hand-woven wool pile, salt-washed for a vintage effect. | **4**. ALEGA TABLE LAMP in glass with a transparent base and opaline glass lampshade.

This page NATALIE ARMCHAIR in leather with a wide seat and front feet on castors. A modern reinterpretation of traditional shapes.

Design **PAOLA NAVONE**

NATALIE

Solidity, comfort and all the beauty of Natuzzi leather. To move wherever you wish.

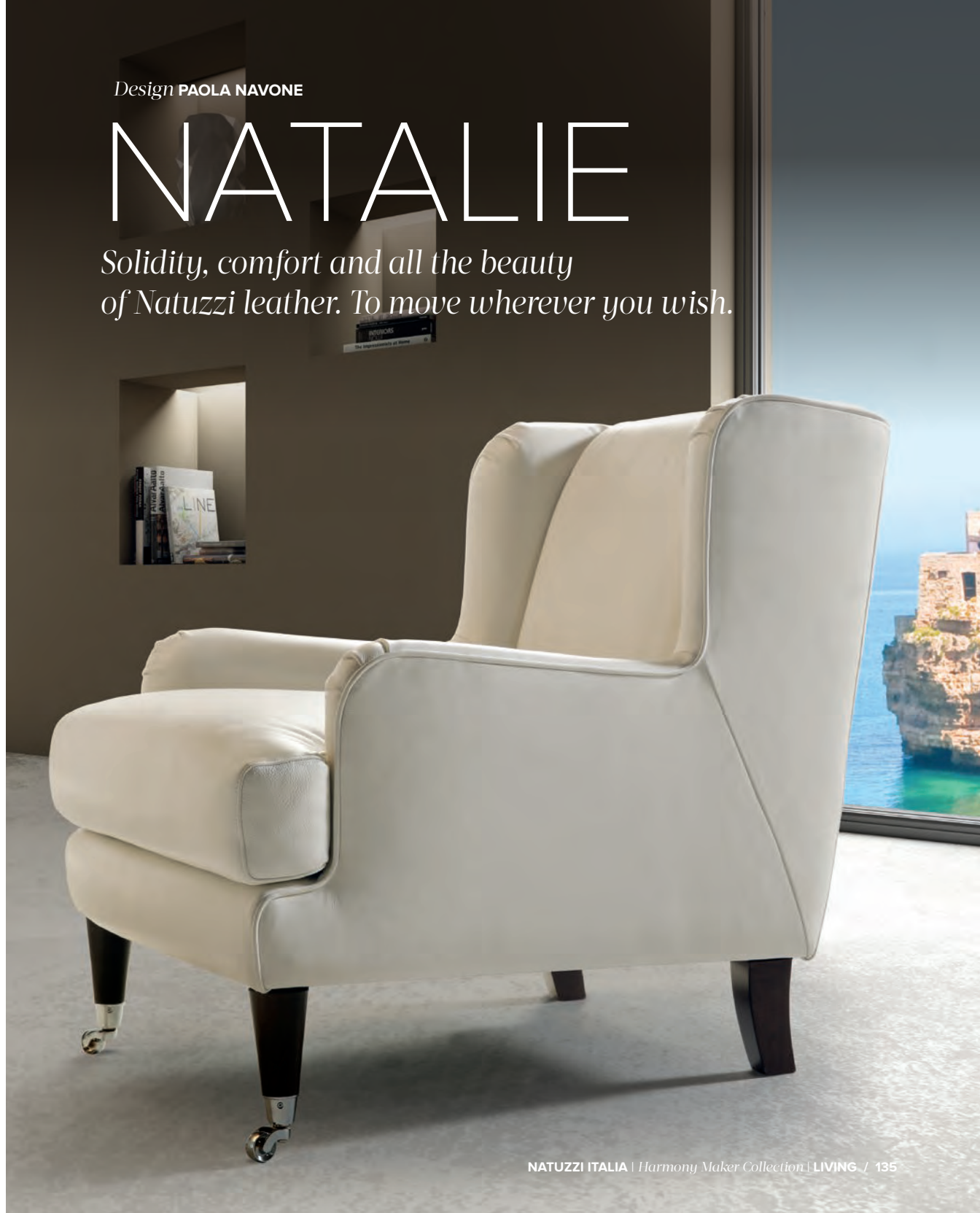

Design **CLAUDIO BELLINI**

AURA

*A seat designed for relaxation,
safe in the embrace
of the padded design.*

1. AURA ARMCHAIR with high backrest or low backrest. Structure in solid wood, available in various finishes.
2. PROXIMA BOOKCASE free-standing with an oak structure and shelves in tempered glass.
3. NESSA LAMP in blown glass.



1. LEYRA ARMCHAIR in fabric, also available in leather. | 2. PLISSÉ BOOKCASE by Victor Vasilev with a free-standing structure in aged walnut and lacquered shelves. | 3. PITAGORA RUG in hand-knotted wool.

Design CLAUDIO BELLINI

LEYRA

Slender feet, accommodating backrest: make yourself comfortable.

2.

1.

3.



Paola Navone.

After graduating from the Polytechnic University of Turin in 1973, Paola Navone began her career working with the best designers of the time. In 1983 she won the Osaka International Design Award, launching a professional journey that continued to flourish. Her creativity draws inspiration from all types of culture, particularly eastern styles, and gives life to projects characterised by a strong originality and carefully chosen international influences. An architect, art director, designer and teacher, Paola Navone is a true professional whose vivacious and eclectic spirit reverberates in each of her creations.

Design **PAOLA NAVONE**

MARLENE

*Nineteenth-century inspiration,
classic and familiar shapes.*

1.



DESIGNER.



1. MARLENE ARMCHAIR in leather with wooden feet. Also available in removable fabric. | **2.** GINGER SIDE TABLE by Paola Navone with an octagonal nickel silver top. | **3.** DORIS SIDE TABLE with an oval nickel silver mirrored glass top with bevelled edge. | **4.** GRACE SIDE TABLE with a decorative top in nickel silver mirrored glass with bevelled edge. | **5.** PITAGORA RUG in wool.



Design **CLAUDIO BELLINI**

DOLLY

2.

*Accommodating and feminine
shapes with the comfort
of Natuzzi padding.*

1.



- 1. DOLLY SOFA**
in leather and in fabric. The mix of polyurethane and memory foam padding guarantees extraordinary comfort, offering support and lasting good looks. The trim, also available in contrasting colours, runs along the outer edge and emphasises the skilful craftsmanship. |
- 2. PROXIMA BOOKCASE**
free-standing with a wood structure and shelves in tempered glass.

Design **CLAUDIO BELLINI**

ANTEPRIMA

*Compact dimensions, refined design.
An armchair for any room of the house.*

2.

1.

1. ANTEPRIMA ARMCHAIR available in fabric and leather. The compact sizes and refined look are enhanced by metal feet embedded in the frame, available in various finishes. | 2. NOVECENTO BOOKCASE modular free-standing wall unit system in wood.



Design MANZONI & TAPINASSI

LOGOS

*Undulating and accommodating shapes.
A deep seat and a welcoming backrest.
In a nutshell, comfort.*

1.

2.

3.



Design NATUZZI DESIGN CENTRE

PLATEA

*Seventies style returns
to give life to timeless comfort.*

This page **1.** PLATEA ARMCHAIR in fabric and in leather. | **2.** ASTRA FLOOR LAMP in steel with an opaline glass lampshade.

Side page **1.** LOGOS ARMCHAIR blending design and pure relaxation, in fabric and leather. The seat features a memory foam insert for added comfort and to ensure lasting good looks. | **2.** HERMAN SIDE TABLES by Manzoni & Tapinassi in metal with a top in smoked oak or satin glass. | **3.** AFFRESCO RUG hand-woven wool pile, salt-washed for a vintage effect.

Design NATUZZI DESIGN CENTRE

ERA

*A new era of simple lines, characterised
by exquisite materials.*

1.



1. ERA CHAIR upholstered in leather
in various colours from the pattern book.

Design MANZONI & TAPINASSI

VIAGGIO

*A wide seat and horizontal shapes:
this is a journey into relaxation.*



1. VIAGGIO ARMCHAIR with a wood structure and metal armrests, in leather and in fabric.
| 2. IDO COFFEE TABLE by Mauro Lipparini with a metal structure and a marble top. | 3. ONDA LAMP in metal.

Design NATUZZI DESIGN CENTRE

REGIA

*A square and functional
armchair with a side pocket
for magazines.*

REGIA ARMCHAIR in leather and in fabric.
Thanks to its simple yet refined lines, this
model adapts to any room and any furnishing
style.





Design **NATUZZI DESIGN CENTRE**

LIU

*Rounded shapes are combined
with a swivel base
to provide comfort and freedom.*

LIU ARMCHAIR with a wide swivel base in metal, in leather and in fabric. The mix of polyurethane, memory foam and feather padding guarantees extraordinary comfort, offering support and lasting good looks.

Design MANZONI & TAPINASSI

CAMMEO

Padded comfort and the lightness of metal combine to create a metropolitan design.



CAMMEO ARMCHAIR in leather and in fabric, with a metal structure and leather upholstery underneath the seat and on the rear of the backrest.

Design MANZONI & TAPINASSI

TRATTO

*Light lines offer
compact and exquisite comfort.*



TRATTO ARMCHAIR in fabric
and in leather with metal feet.

Design MAURO LIPPARINI

ILIA

*The most welcoming design,
an experience
of incredible softness.*



ILIA RECLINER ARMCHAIR in fabric and in leather. The mix of padding that combines expanded polyurethane and Climalight (a special silicone-treated microfibre) guarantees extraordinary comfort, offering support and lasting good looks. The grosgrain piping emphasises the lines. Electric recline function with an inbuilt rechargeable battery which activates the footrest and backrest separately. The headrest is adjusted manually to obtain the desired position. Wooden frame in various finishes.



Watch the video.

Design MANZONI & TAPINASSI

NOTE

*An armchair that engulfs
you in pure relaxation,
whatever the occasion.*



1. NOTE ARMCHAIR in leather with a metal swivel base, characterised by a high backrest and an accommodating seat. Also available in fabric. | 2. MONDRIAN CHEST OF DRAWERS by Claudio Bellini with a metal base and lacquered structure.

Design MANZONI & TAPINAS

SOUND

*A technological cocoon
where you can lose yourself and
discover all the melodies of comfort.*



2.



1.

1. SOUND ARMCHAIR in leather with audio system. The speakers are built into the headrest, while the perforations in the upholstery enhance the three-dimensional sound. Also available in fabric with audio system and swivel base. | 2. CABARET COFFEE TABLE with a metal structure and lacquered glass.



Watch the video.

Design **NATUZZI DESIGN CENTRE & FORMWAY**

RE-VIVE

*The icon of Natuzzi's
harmony and innovation.*





Watch the video.

TECHNOLOGY



1. YOU MOVE. Re-vive moves with you. Automatically, without activating a lever or external mechanism.

2. LOSE YOURSELF IN THE FORCE OF GRAVITY. Re-vive activates a light oscillating movement.

3. YOU RECLINE, LIE DOWN, CURL UP. The Re-vive spine mirrors your own, offering constant support.

4. YOU CHOOSE THE POSTURE. Re-vive follows your movements, combining rotation, lumbar motions and reclined positions.

5. RELAX FREELY. The dynamic armrests follow you, seamlessly sliding into position.

6. YOU TURN, TURN, TURN. Re-vive turns with you, naturally rotating a full 360° in complete safety.

7. LET GO AND LOSE YOURSELF IN RELAXATION. Re-vive supports you with padding that moulds to your body.

8. YOU RELAX, YOU REST, YOU FALL ASLEEP. The footrest supports your feet, adapting to your every move.

9. SIT DOWN HOWEVER YOU LIKE. Re-vive follows you fluidly and naturally, without jerks or shocks.

MEET CRAFTSMANSHIP



Re-vive skilfully combines the best Italian craftsmanship and manufacturing traditions with revolutionary technology, developed in collaboration with Formway Furniture, a New Zealand-based company at the cutting edge of ergonomic and innovative armchair design.





RE-VIVE is the only armchair in the world that adapts to any seating position. Curled up, stretched out, crouched, head down...finally, everyone can indulge in complete relaxation, exactly how they like it. | RE-VIVE QUILTED with footrest, Queen version in leather and in fabric.



Watch the video.

WITH OUR ADVANCED TECHNOLOGY WE HAVE CRAFTED A LEVEL OF COMFORT SO PROFOUND THAT YOU CAN DETACH FROM EVERYTHING AROUND YOU, WHILE STILL EXPRESSING YOUR PERSONALITY.

INFINITE CUSTOMIZATION POSSIBILITIES, ONE RE-VIVE.

DESIGN, UPHOLSTERY, DIMENSIONS.
COLOURS, DETAILS, FINISHES. A THOUSAND POSSIBILITIES
IN ONE ARMCHAIR: YOU DECIDE.

1. THE PERSONALISATION BEGINS WITH THE DESIGN, crafted to satisfy every stylistic taste. More welcoming, more contemporary, softer, more linear.

2. KING OR QUEEN? Choose your ideal seat size for maximum comfort.

3. LEATHER OR FABRIC: you choose the right upholstery for you.

4. A MYRIAD OF COLOURS is available, selected after a careful study of international colour trends.

5. THE FEET OF EACH RE-VIVE ARMCHAIR ARE SUPPORTED BY A BASE which mirrors it's movements. Choose from 5 exquisite finishes to find the right design for you.

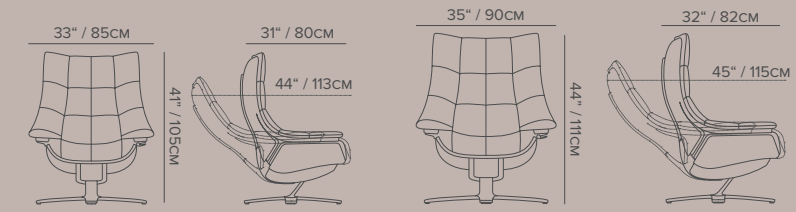

QUEEN VERSION

KING VERSION



CLUB



WING BACK



LOUNGE



QUILTED



RE-VIVE LOUNGE with footrest, Queen version
in 106 colours of leather and in 122 colours of
fabric.



A close-up photograph of a wooden dining table. The top edge of the table is visible, showing a dark wood grain. Below it, a thick, square wooden leg is shown, also with a dark wood grain. The background is dark and out of focus.

Dining



Bernhardt & Vella.

A partnership forged in Milan in 2008 which combines the experience and creativity of Ellen Bernhardt and Paola Vella. Their work is expressed in numerous fields, a testimony their professional eclecticism which ranges from industrial product design and visual communication to interior design and furnishings.

Design BERNHARDT & VELLA

ACCADEMIA

Lines and details result in the skilled tradition of cabinet-making create elegant and visually interwoven designs.

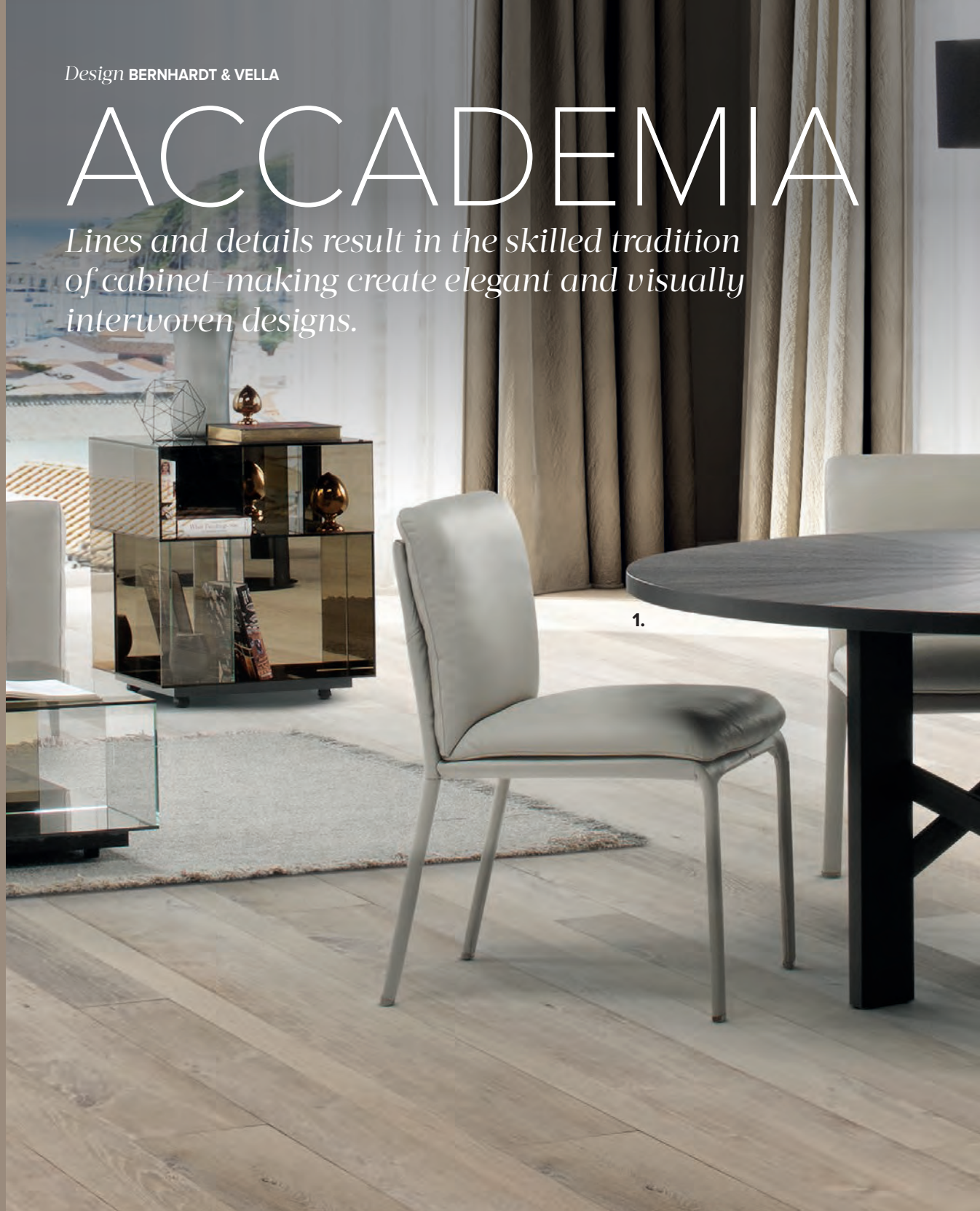

1.

DESIGNER.



2.

- 1. ACCADEMIA TABLE round version with a veneered oak base and top. The top is characterised by a unique wedge design.
- | 2. ACCADEMIA BUFFET CABINET with a veneered oak structure, open cabinets and drop-down doors.
- | 3. AMBRA CHAIR with a padded backrest and seat upholstered in leather or fabric in a choice of colours from the pattern book. Also available with armrests.

3.

3.





1. ACCADEMIA TABLE square, in oak. The special craftsmanship of the top creates an interesting dynamic effect. | **2.** SONATA CHAIR with a solid oak structure and padded seat and backrest upholstered in leather. Available with and without armrests, also available in fabric in various colours from the pattern book. | **3.** KUBIKA MODULAR WALL by Pierangelo Sciuto with a structure in smoked oak and door cabinets with coffee-coloured lacquered doors and black chrome-effect metal.

1./2./3. ACCADEMIA TABLE
rectangular version in wood, also
available in the extendable
version with an aluminium
honeycomb top.

| 4. SIGMA CHAIR with leather
seat and backrest. Also available
in fabric and leather in various
colours from the pattern book.

4.

1.





< E X T E N D A B L E >





Design VICTOR VASILEV

LEGGERO

*Simplicity and elegance
come together in a creation
that dominates the dining room.*



1. LEGGERO TABLE in aged walnut veneer with solid wood feet. Also available in the extendable version with a lateral opening mechanism in anodised aluminium that extends the surface by 60 cm. | 2. LISA CHAIR by Victor Vasilev with a solid wood structure in anthracite matt lacquer with a leather seat. Available in various colours and with the seat upholstered in fabric.

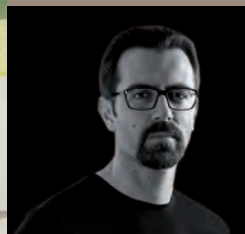

Victor Vasilev.

Born in Plovdiv, Bulgaria in 1974, Victor Vasilev is a designer and architect who constantly seeks simplicity of shapes and materials. Having graduated from Milan Polytechnic University, he attended the Academy of Fine Arts in Copenhagen then opened his studio in Milan in 2004, receiving numerous international accolades.



Watch the video.

DESIGNER.



1.

Design **CLAUDIO BELLINI**

SATURNO

Simple design and Italian excellence, crafted to offer the warmest conviviality.



1. SATURNO TABLE
rectangular with legs
and side edges in solid
Italian walnut and a satin
fingerprint-free etched
glass top. Also available
as a square version and in
various veneers.
2. PIGRECO CHAIR with
leather seat and backrest.
Also available in fabric.



An interplay of geometric shapes formed from straight and curved lines blend with the wood and satin glass: Saturno offers an interpretation of blended refinement which adds value to any dining room.





FORTUNA SIDEBOARD with a satin fingerprint-free etched glass top. Structure and legs in solid Italian walnut. The sideboard features soft closing drawers and storage compartments with hinged doors. Interiors in matt lacquer.

Design NATUZZI DESIGN CENTRE

HARLEM

The geometric base brings a dynamic element to the striking wooden top.

1. HARLEM TABLE with a structure and top in smoked oak, varnished with a scratch-resistant finish. The base features an interesting combination of wood and lacquer which characterises the design.
2. BRERA CHAIR with a solid ash base in a smoked oak finish. Padded seat cushion upholstered in leather. Also available without armrests.
3. NOVECENTO BOOKCASE with a smoked oak finish and door cabinets with glossy lacquer doors.





1.

1.



Design NATUZZI DESIGN CENTRE

HEX

*Characterised by an unusual hexagonal shape,
this table is the star of any living area.*



2.



3.

1. HEX TABLE fixed with a solid wood structure and top in extra-clear or tinted tempered glass. | 2. HEDI CHAIR padded, available in leather and in fabric. | 3. KUBIKA MODULAR WALL by Pierangelo Sciuto, wall unit system composed of modular elements, open cabinets and door cabinets available in different sizes which can be combined in a customizable way.

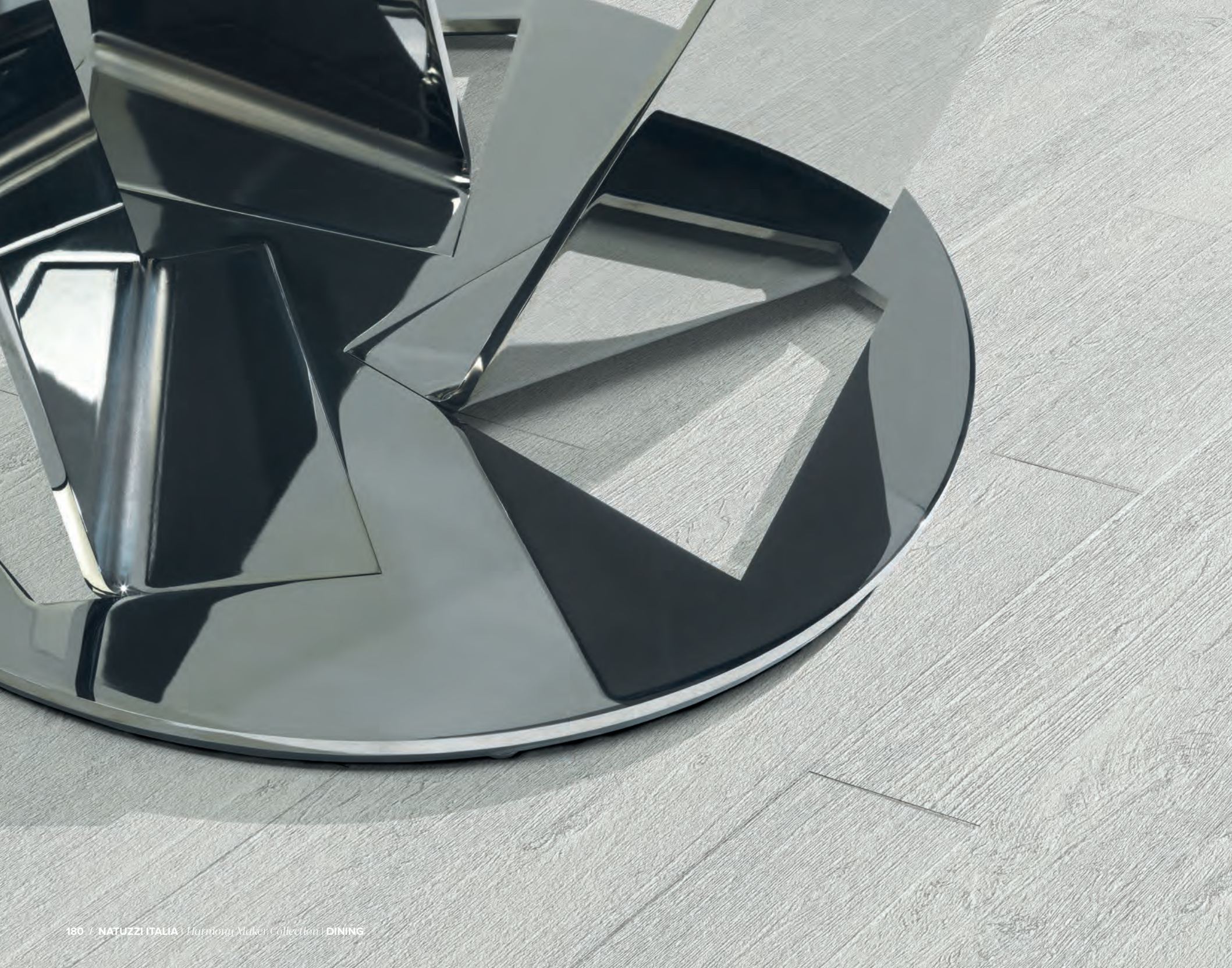

Design **CLAUDIO BELLINI**

RAMO

*An effective design that evokes the branches
of a majestic tree.*



1.

2.

1. RAMO TABLE with a metal base characterised by a special hot-dip galvanizing process, which enhances the colours and defines the look. Top in extra-clear tempered glass. Also available in a rectangular version. | 2. SIGMA CHAIR with a leather seat and backrest. Also available in fabric and leather in a choice of colours from the pattern book.



< E X T E N D A B L E >



Design **CLAUDIO BELLINI**

CONVIVIO

A contemporary design, geometric base and extendable top.



1./2./3. CONVIVIO TABLE extendable with a varnished structure in an anthracite finish and a top in extra-clear or tinted tempered glass. | 4. SIGMA CHAIR in leather, also available in leather or fabric in a choice of colours from the pattern book.





Bed

Design BERNHARDT & VELLA

FENICE

A bed offering renewed life every day, in a striking and original geometric design.



1.



4.





1. FENICE BED available in 106 colours of leather and 122 colours of fabric, also available with removable fabric, with or without storage container. A choice of 4 dimensions with or without mattress. Metal feet at the corners. | 2. KUBIKA BEDSIDE TABLE by Pierangelo Sciuto with a structure in smoked oak and drawers in a coffee-coloured matt lacquer finish. | 3. AURA ARMCHAIR by Claudio Bellini in fabric, also available in leather. | 4. AFFRESCO RUG hand-woven in wool pile, salt-washed for a vintage effect. | 5. ONDA TABLE LAMP with a metal structure and lampshade in a soft-touch finish.

5.

3.





3.

1. THE OPENING MECHANISM

to access the storage container offers a choice of two positions: the first enables you to make the bed without having to bend down, while the second lets you effortlessly arrange objects and linen anywhere in the compartment. | **2. LABIRINTO ROTATABLE BOOKCASE** by Claudio Bellini in thin tinted glass with a unique multi-coloured design. | **3.** The feather and polyurethane padding of the headboard is fully upholstered in leather.



Claudio Bellini

Living and working in Milan, the city of design, Claudio Bellini's focus on creativity began early in his childhood thanks to his father Mario Bellini, an influential figure in the world of Italian design which so inspired him. Having founded the Claudio Bellini Design Studio in 1996, the designer immediately focused his attention on research, new technologies and creative processes.

Design **CLAUDIO BELLINI**

PIUMA

*With a trim inspired by softness,
this bed offers the lightest and most
welcoming of rests.*



DESIGNER.

1. PIUMA BED available in 4 sizes with or without mattress, in leather and in fabric. Fully padded headboard and base. The velvet trim detail which runs along the outer edge of the bed brings the promise of even deeper relaxation to the model. | 2. MONDRIAN CHEST OF DRAWERS by Claudio Bellini in grey matt lacquer. Available with a metal base and structure in matt lacquer. The Mondrian bedside unit is characterised by a clean and minimalistic design. The variety of designs and finishes makes it extremely versatile and adaptable to any taste and any space. | 3. MONDRIAN BEDSIDE TABLE by Claudio Bellini with a metal base and structure in grey matt lacquer. | 4. VELIO RUG hand-knotted on a loom.





4.

2.

3.

5.

Design MANZONI & TAPINASSI

DOLCE VITA

*The comfort of the padding and a retro-glam style
bring a Fellini-inspired atmosphere to the room.*



1.

6.

1. DOLCEVITA BED available in 4 sizes with or without mattress, in leather and in fabric.
| 2./3. HERMAN SIDE TABLES by Manzoni & Tapinassi with top in wood or glass.
| 4. LOGOS ARMCHAIR in fabric. | 5. AFFRESCO RUG hand-woven wool pile, salt-washed for a vintage effect. | 6. ALEGA TABLE LAMP in glass.

1.





1. Headboard with detailed quilting to give the bed a luxurious character. The metal feet bring slenderness to the design. | 2. MUNARI CHEST OF DRAWERS by Manzoni & Tapinassi in wood with a Dark Emperor marble top. | 3. MUNARI BEDSIDE TABLE by Manzoni & Tapinassi in wood with a Dark Emperor marble top.



Design **CLAUDIO BELLINI**

ONDA

*The name is inspired by the headboard
and its flowing horizontal quilting.*





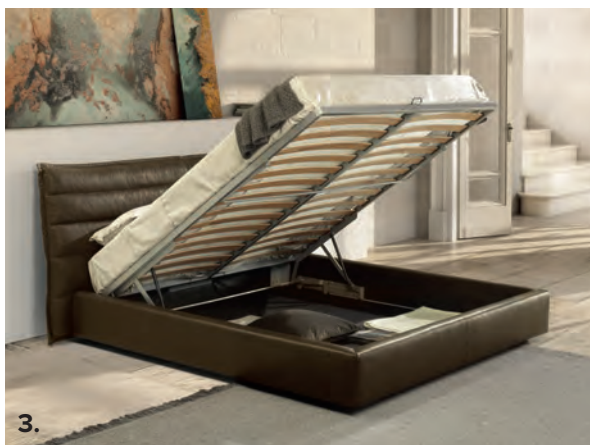

1. ONDA BED available with or without door cabinet, in 4 sizes with or without mattress, in leather and in fabric. Fully padded headboard and base. | 2./3. THE OPENING MECHANISM to access the storage compartment offers two possible positions: the first enables you to make the bed without the need to bend down, while the second lets you effortlessly arrange objects and linen anywhere in the compartment. | 4. MARLENE ARMCHAIR by Paola Navone available in removable fabric, and leather. | 5. PITAGORA RUG in hand-knotted wool. | 6. HERMAN SIDE TABLE with a metal structure and glass top. | 7. The padded headboard with horizontal stitching emphasises the skilled craftsmanship of the model.



Watch the video.



7.



SVEVO BED available in 4 sizes, with leather upholstery and in removable fabric.

Design MANZONI & TAPINASSI

SVEVO

A 1950s-inspired furniture collection characterised by elegant lines. Also available for the bedroom.





1.



2.



3.

4.

1./2. SVEVO CHEST OF DRAWERS in wood, lacquer and glass. The bedside unit is characterised by solid wood feet in various finishes, enhanced by a metal insert. Matt lacquer drawers available in various colours. | 3. SVEVO BEDSIDE TABLE in smoked oak/ grey matt lacquer. | 4. ONDA LAMP available in various sizes and finishes. | 5. The solid wood feet with the metal detail are the distinctive feature of the Svevo unit, creating a majestic and visual solidity.



5.



2.

3.

5.

Design **CLAUDIO BELLINI**

VELA

*A padded bed
for an elegant voyage.*



4.

1.

Previous page **1.** VELA BED in leather, also available in fabric, in various sizes with or without mattress. The headboard can be manually adjusted to adapt perfectly and comfortably to your desired position, making the bed the perfect place to read and work.

- | **2.** ANTEPRIMA ARMCHAIR in leather and in fabric. | **3.** MERIDIO SIDE TABLE with a chrome metal structure and matt lacquer top. | **4.** ELSA READING LAMP with a metal stand and lampshade. | **5.** PITAGORA RUG in hand-knotted wool.



This page **1.** The rear of the headboard features useful storage compartments to store pillows, blankets or sheets. Metal structure and feet. | **2.** Detail at the base of the bed, padded and upholstered on each side. | **3.** The cushions of the headboard feature a unique metal zip.



Watch the video.



3.

Design MANZONI & TAPINASSI

DIAMANTE

An upholstered bed, studded like a precious jewel into the frame.



1.

3.



1. DIAMANTE BED available in various sizes, in leather, and in fabric. Fully padded and upholstered headboard and sides. The lacquered metal feet bring lightness to the design. | 2/3. EUCLIDE CHEST OF DRAWERS AND BEDSIDE TABLE with lacquered feet and structure. The line of the feet is an integral part of the structure and characterises the model. | 4. NATALIE ARMCHAIR by Paola Navone in leather. | 5. PITAGORA RUG in hand-knotted wool.

2.

4.

5.



1. THE NATUZZI ITALIA LINEN COLLECTION features 100% Italian-made bedding sets.
| 2. ONDA TABLE LAMP in metal.
| 3. Curved headboard and skilful stitching bring elegance and refinement to the model.





3.

MATERIALS.

*Natuzzi Italia materials are characterised
by superb quality and tactile textures.
A pattern book that offers something for everyone.*

Material has always been an important source of inspiration for our collections, distinguished by the use of materials of unparalleled quality anywhere in the world. There are infinite combinations of shapes and colours, skilfully blended and defined by the Natuzzi Style Centre: untreated wood is combined with extra glossy lacquers, the most exquisite marbles are paired with tempered steel, warm natural essences are

placed side by side with glossy or satin-finished metals. It is a unique heritage which allows everyone to use the materials that best suit their personality and home. There is a vast selection of styles waiting for you in our Natuzzi Italia stores where, together with our consultants, you can work with our Design Studio to create your own space in 3D and in real time.





LEATHER.

Leather has been with us every step of the way: its beauty has characterised the success of Natuzzi Italia collections since the very beginning, emphasising elegance, shape and multisensory comfort.

LEATHER IS ALIVE.

It breathes, it is generous and sincere; it never hides its natural blemishes in undeniable proof of its authenticity.

WE KNOW HOW TO WORK WITH LEATHER.

Our master tanners select the best hides and bring out their best characteristics thanks to our exclusive tanning process perfected through years of experience.

OUR LEATHER IS SAFE.

We tan our leather in accordance with European environmental regulations which are among the most rigorous in the world. As a result, our upholstery is completely toxic-free, water-repellent and resistant to wear.

NATURAL LEATHER.

Those who wish to enhance the aesthetics of their sofa with an exquisite material can choose the unparalleled softness of a Natural Leather.

PROTECTED LEATHER.

Those who love leather but need a water-resistant and hard-wearing material can choose from our range of Protected Leathers, which are especially suited to homes with children and pets.

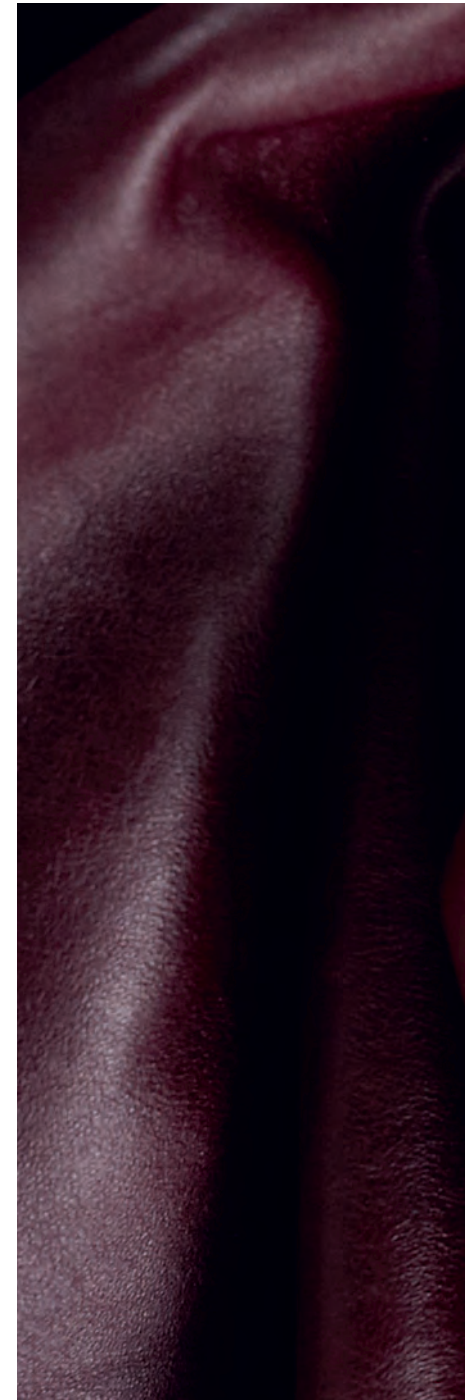







FABRICS.

*You can recognise our fabrics with a single touch.
Our natural and technical fabrics are characterised by
an unmistakable tactile quality.*

The Natuzzi pattern book offers a wide range of styles designed for every lifestyle and furnishing taste. The quality of natural fabrics is complemented by the performance of technical fibres, enabling you to choose the upholstery or rug that best suits your home.

Linen, wool, silk and cotton are woven into rugs and upholsteries distinguished by an exquisite natural quality. Viscose, velvets and microfibres ensure optimum washing resistance and durability.





PADDING.

The Comfort Division in our Research and Development department defines the best combination of materials for each model, emphasising comfort and design.

ECOFLEX POLYURETHANE

Polyurethane is a hypoallergenic, anti-bacterial, flexible and reliable rubber. Our polyurethane is manufactured in our Natuzzi factories without the use of Freon or other potentially harmful chemicals.

MEMORY FOAM

Polyurethane that adapts its shape to the weight it supports. This characteristic enables it to adapt to your body, guaranteeing exceptional comfort.

CLIMALIGHT: PADDING FOR THE NEXT GENERATION.

Composed of a special blend of microfibre and polyester, this innovative material guarantees an enveloping “feather effect” which is ergonomic, breathable and completely hypoallergenic.

FEATHER

The goose feathers used in our padding are Class 1 (ref. UNI EN 12934/01): hypoallergenic and fire-resistant, it is subjected to numerous sterilisation, heat and washing treatments to ensure maximum hygiene.

WOOD.

The warmth and natural elegance of wood comes into the home, enhancing any space.

Walnut, oak, ash. The timeless elegance of natural materials paired with the modernity of lacquered wood. Tables, chairs, sideboards and bookcases are characterised by a material warmth and versatility. Wood is

expressed in all its potential, with a broad range of classic finishes, exquisite details and crafted styles in line with the most avant-garde furnishing trends, enhancing our homes with a material that never ceases to amaze.

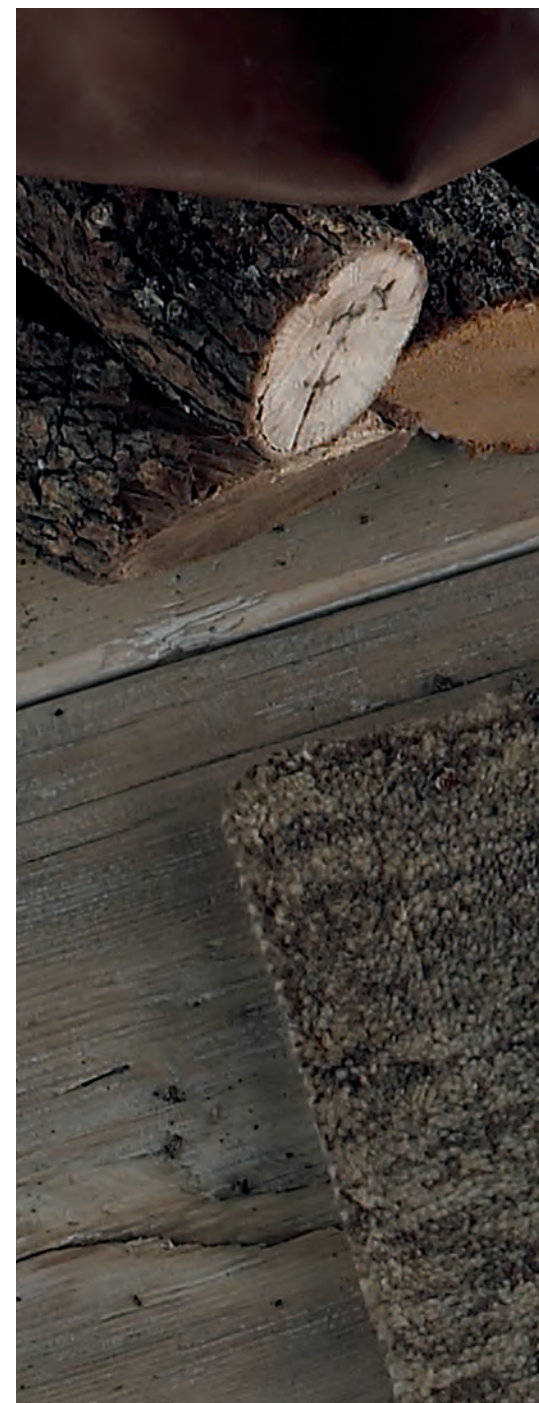



ONLINE DESIGNER: BRING YOUR PROJECTS TO LIFE.

A pattern book of 106 leathers and 122 fabrics.
An almost infinite range of finishes for wood, metal, glass
and marble. A veritable collection within a collection,
which you can discover and apply using our new
online designer.

Start designing at www.natuzzi.com

TECHNICAL SPECIFICATIONS.

SOFAS	224
ARMCHAIRS	254
COFFEE TABLES	261
LAMPS	266
RUGS	269
SHELVING UNITS AND BOOKCASES	274
TABLES AND CHAIRS	277
SIDEBOARDS AND BUFFET CABINETS	282
BEDS	283
BEDROOM ACCESSORIES	289



Sofa available in linear or corner versions, with or without chaise longue. Upholstery in removable fabric or exquisite Natuzzi leather. The mix of polyurethane, feathers and memory foam padding guarantees extraordinary comfort, offering support and lasting good looks. The grosgrain piping enhances the model and emphasises the accommodating shapes. The grosgrain can be in matching or contrasting colours to suit any style. The wide and generous seats offer maximum comfort. This is a modular model offering personalised arrangements to match the space and provide the desired comfort. Each individual element is finished on each side so it can also be used as a standalone piece.

STANDARD VERSIONS



MODULAR ELEMENTS

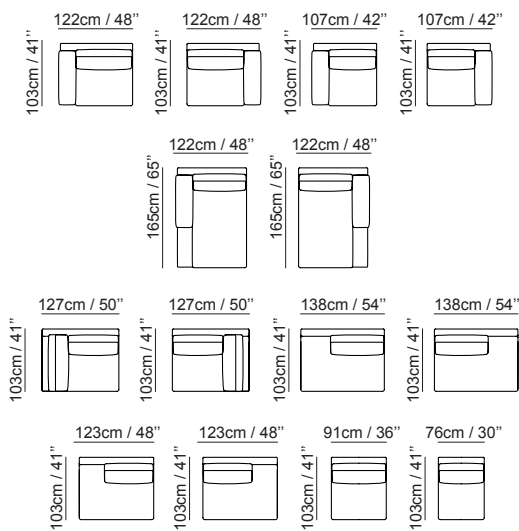

SUGGESTED COMPOSITIONS

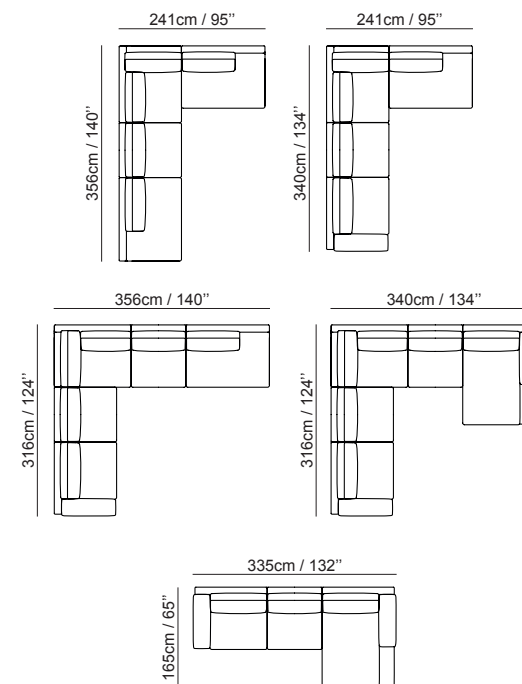



Sofa available in linear or corner versions, with or without chaise longue. Upholstery in exquisite Natuzzi leather. The metal tubing which runs along the armrest and side of the sofa matches the metal insert of the wooden feet. Stitching also available in contrasting colours. Manually adjustable headrest. Quilted seat cushion to emphasise the refinement and craftsmanship of the piece. Wooden feet in various finishes with metal inserts.

STANDARD VERSIONS

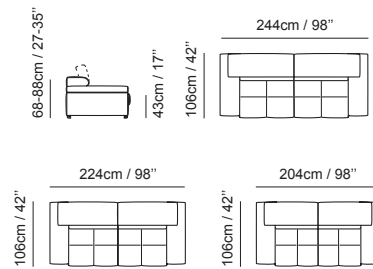

MODULAR ELEMENTS

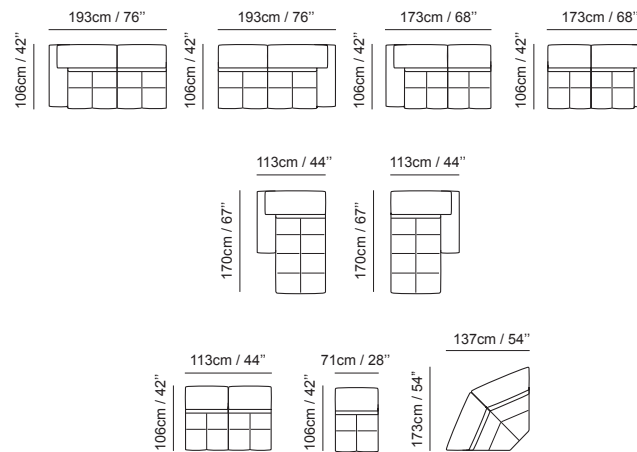

SUGGESTED COMPOSITIONS

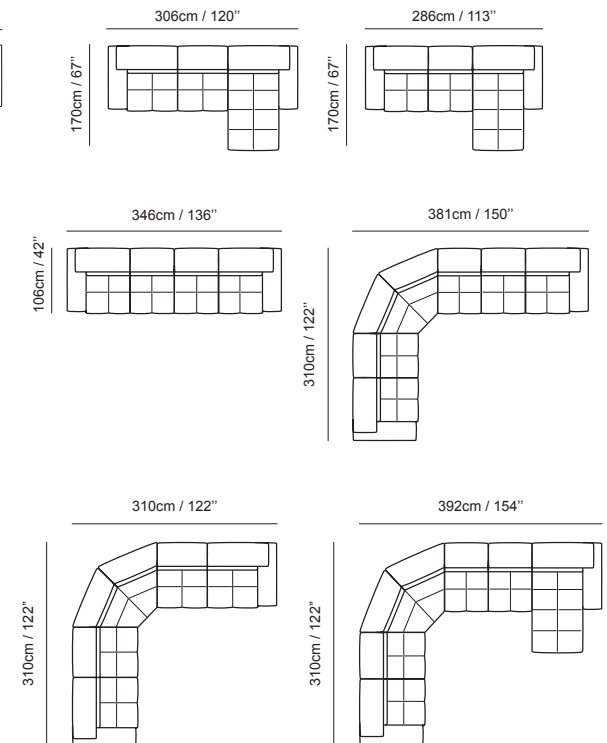



Sofa available in linear or corner versions, with or without chaise longue. Upholstery in fabric or exquisite Natuzzi leather. The mix of polyurethane and memory foam padding guarantees extraordinary comfort, support and lasting good looks. Adjustable headrest on each seat to provide tailor-made comfort. The leather version features zigzag stitching which enhances the style of the sofa and emphasises the skilled craftsmanship. Available with a solid wood or metal base.

STANDARD VERSIONS

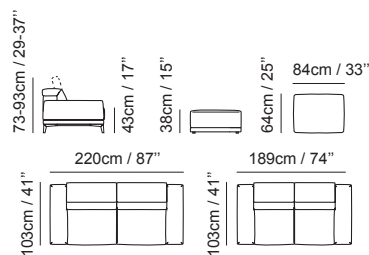

MODULAR ELEMENTS

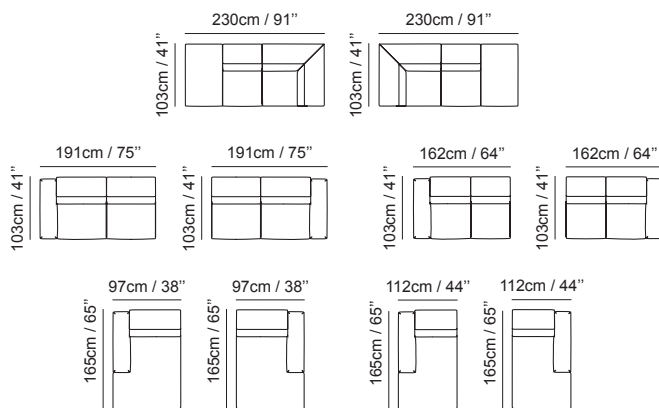

SUGGESTED COMPOSITIONS

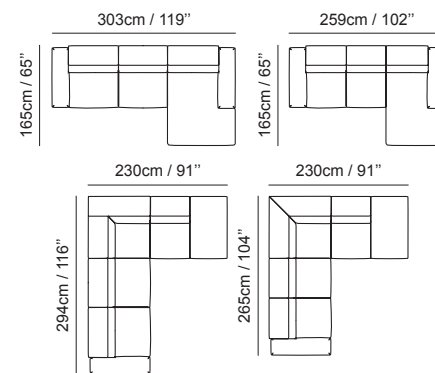



Sofa available in linear or corner versions, with or without chaise longue. Upholstery in fabric or exquisite Natuzzi leather. The mix of polyurethane and memory foam padding guarantees extraordinary comfort, offering support and lasting good looks. The side stitching of the leather version and the exquisite stitching on the armrests and cushions enhance the design and shape. Adjustable headrest on each seat (except corner elements) to provide tailor-made comfort. Also available with a Bluetooth-activated Audio System with in-built speakers. The pinched stitching enhances the style of the model. Soft Touch mechanism available for each seat: the recline function is activated with a single touch to adjust the seat, backrest and footrest simultaneously. The recline function can also be activated manually (by lever) and is also available for the chaise longue element. The space-saving Zerowall system activates the recline function without the need to position the sofa away from the back wall.

STANDARD OR RECLINER VERSIONS

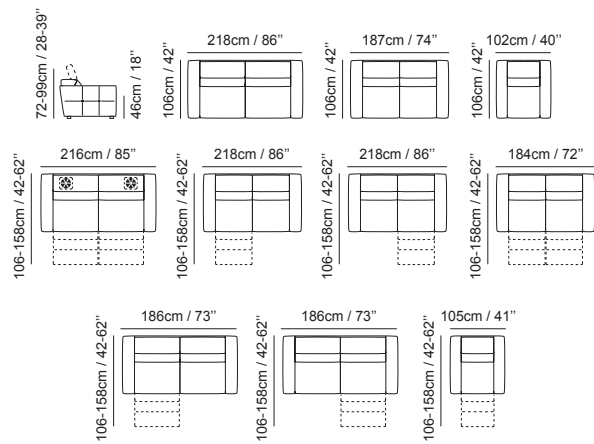

MODULAR ELEMENTS

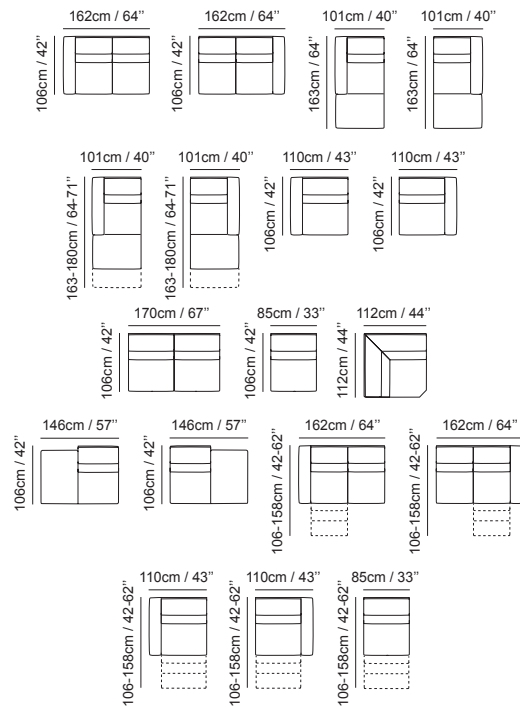

SUGGESTED COMPOSITIONS

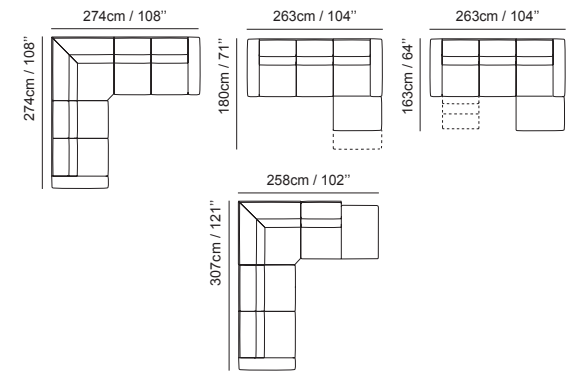



Sofa-bed available in linear or corner versions, with or without chaise longue. Upholstery in fabric or exquisite Natuzzi leather. Recline function, bed and chaise longue frame available for all compositions. Adjustable headrest for each seat (except corner elements). Antibacterial and hypoallergenic Greenplus mattress. Wooden feet in various finishings. Soft Touch mechanism available for each seat: the recline function is activated with a single touch to adjust the seat, backrest and footrest simultaneously. The recline function can also be activated manually (by lever). The frame is available in matching or contrasting colours.

STANDARD OR RECLINER VERSIONS

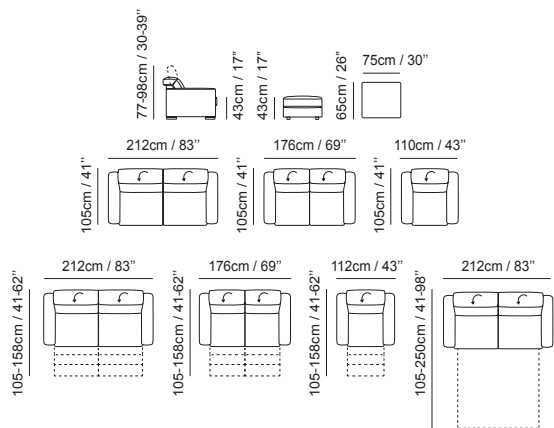

MODULAR ELEMENTS

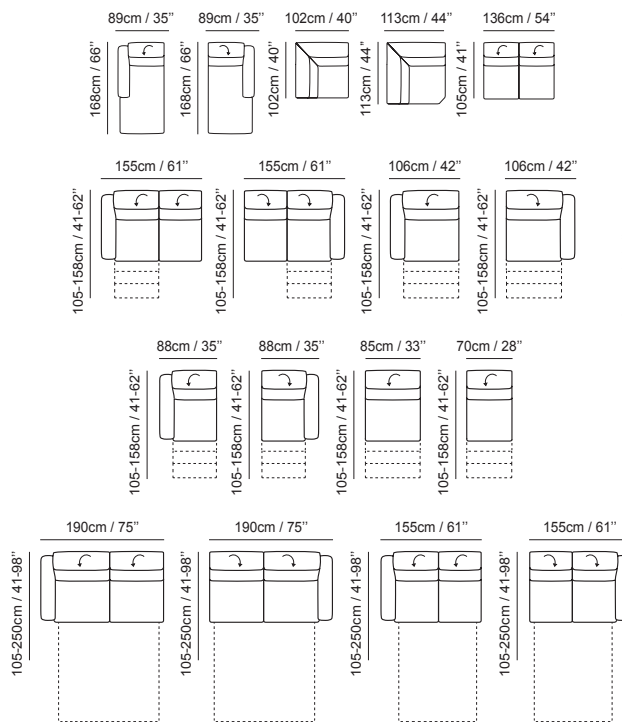

SUGGESTED COMPOSITIONS

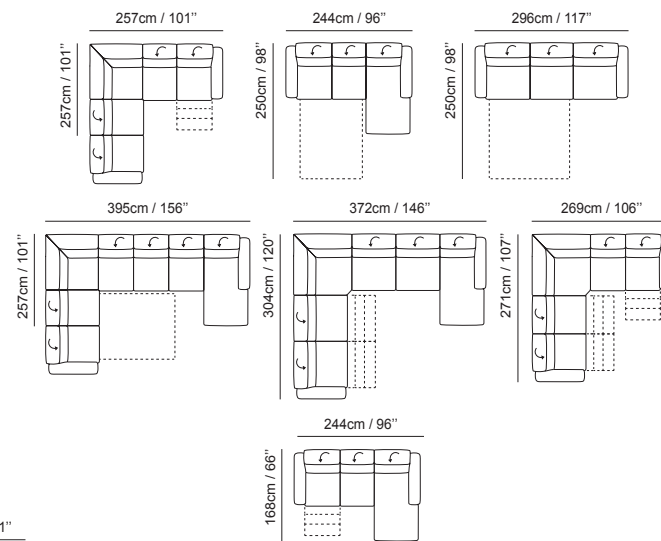



Sofa available in three-seater or two-seater versions. Upholstery in fabric or exquisite Natuzzi leather. The absence of seams and stitching on the seat cushions and the backrest is synonymous with the clean simplicity of the shape. The mix of polyurethane and Memory Foam padding guarantees extraordinary comfort, support and lasting good looks. The padded feather lumbar cushions offer more relaxing comfort. The optional trim along the armrests and seat cushions is also available in contrasting colours to emphasise the flowing lines of the sofa. The metal feet streamline the model.

STANDARD VERSIONS

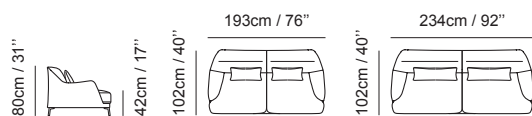



Sofa available in linear and corner versions. Upholstery in fabric or exquisite thickened Natuzzi leather. The mix of polyurethane, memory foam and feather padding guarantees comfort, support and lasting good looks. Thanks to its extreme versatility, the model can adapt to any space. The single elements, exquisitely finished on each side, can also be used as standalone pieces. The hidden non-slip and scratch-resistant foot ensures stability and protects the floor surface. The model is also available with raw-cut stitching when upholstered in exquisite thickened or natural Cassidy leather or the innovative Manopesca fabric.

STANDARD VERSIONS

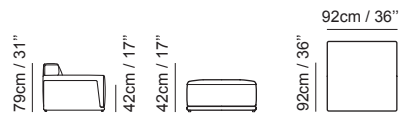

MODULAR ELEMENTS

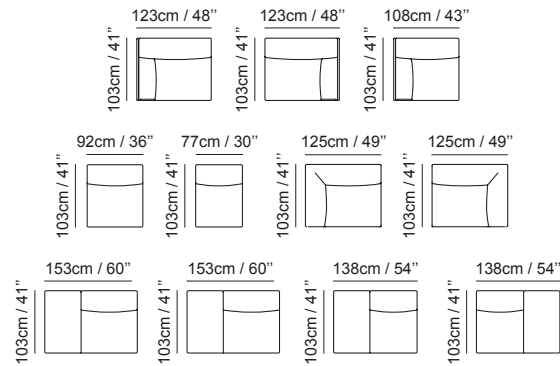

SUGGESTED COMPOSITIONS

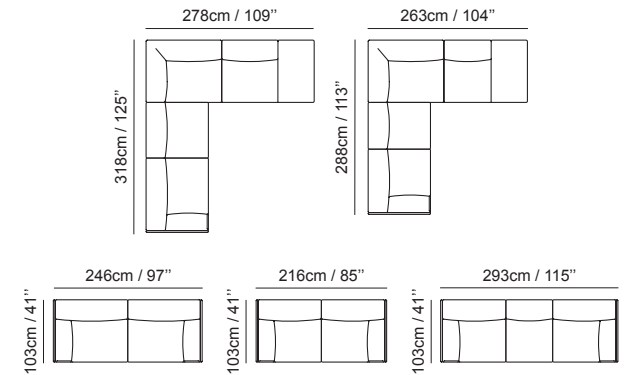



Sofa available in linear versions. Upholstery in fabric or exquisite Natuzzi leather. The mix of polyurethane and memory foam padding guarantees extraordinary comfort, offering support and lasting good looks. Optional audio system with in-built speakers with USB, Bluetooth, AUX and iOS compatibility. The high metal feet enable easy cleaning under the sofa. The skilful stitching on the sides and cushions enhances the design of the model. Soft Touch mechanism available for each seat: the recline function is activated with a single touch to adjust the seat, backrest and footrest simultaneously. The space-saving Zerowall system activates the recline function without the need to position the sofa away from the back wall. Adjustable headrest on each seat and hidden storage compartment inside the broad armrest.

STANDARD OR RECLINER VERSIONS

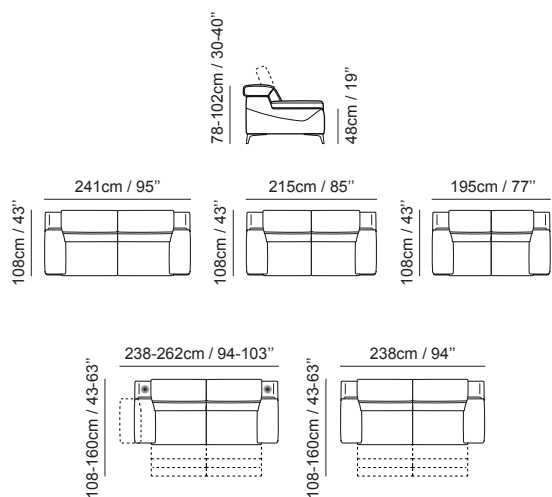



Sofa with individually activated recline function on each seat. Upholstery in exquisite Natuzzi leather. The mix of expanded polyurethane and memory foam padding guarantees excellent comfort, durability and lasting good looks. The pinched or raw-cut stitching demonstrates the manufacturing quality of Italian-made Natuzzi designs and are testimony to our history of working with leather. Available with Soft Touch mechanism to activate the recline function, adjusting the seat, backrest and footrest simultaneously. The mechanism is also available with rechargeable batteries to avoid unsightly cables when the sofa is positioned in the middle of a room. The model is also available with the space-saving Zerowall system which activates the recline function without the need to position the sofa away from the back wall.

STANDARD OR RECLINER VERSIONS

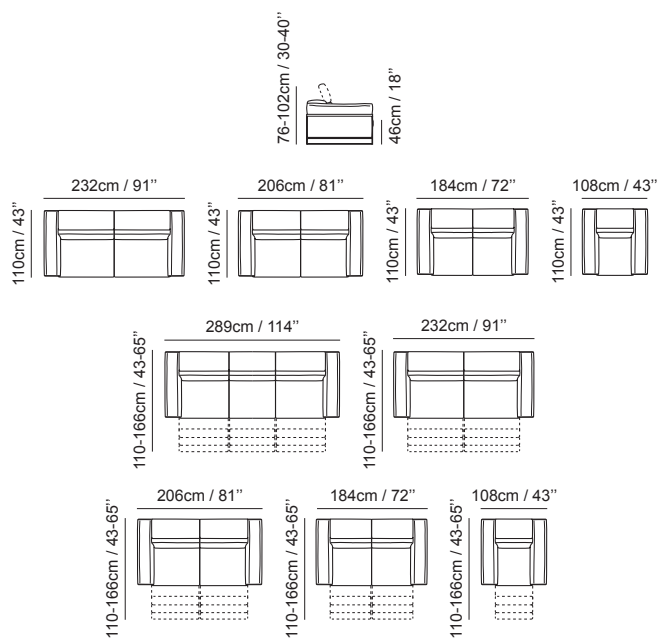



Sofa available in linear or corner versions, with or without chaise longue. Upholstery in fabric or exquisite Natuzzi leather. The single elements are exquisitely finished on each side and can also be used as standalone pieces. Choose your desired comfort level with or without Memory Foam. The trim, also available in contrasting colours, emphasises the geometric shapes and the skilled craftsmanship of the model.

STANDARD OR RECLINER VERSIONS

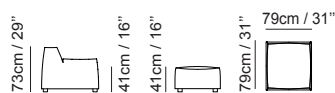

MODULAR ELEMENTS

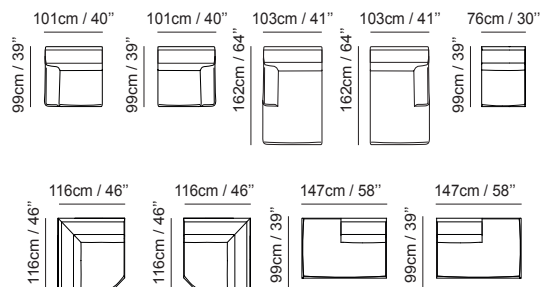

SUGGESTED COMPOSITIONS

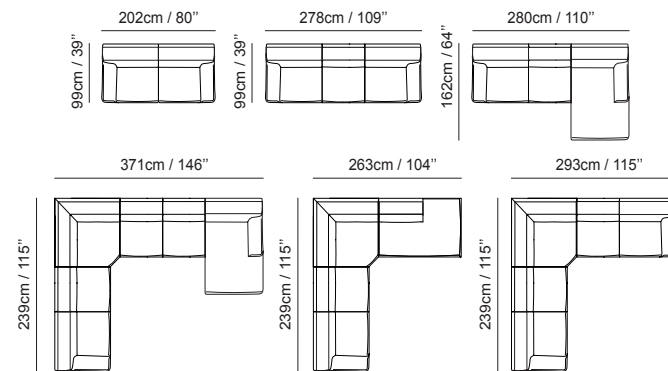



Sofa available in three-seater, three-seater with two cushions and two-seater versions. Upholstery in fabric or exquisite Natuzzi leather. The mix of polyurethane, feathers and memory foam padding guarantees extraordinary comfort, offering support and lasting good looks. The base and feet are available in different types of solid wood and finishes for added originality and are enhanced with metal inserts. The robust shapes, the mix of exquisite materials and the balanced proportions make this sofa the timeless star of any living area.

STANDARD VERSIONS

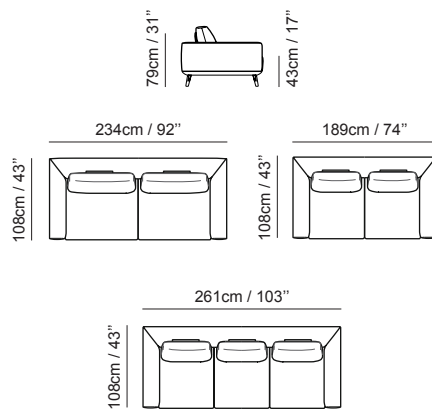



Sofa available in linear, corner and armchair versions. Upholstery in fabric or exquisite Natuzzi leather. The metal feet bring lightness and elegance to the model. The stitching along the edge enhances the design, while the armrest embedded into the frame adds originality to the sofa.

STANDARD VERSIONS

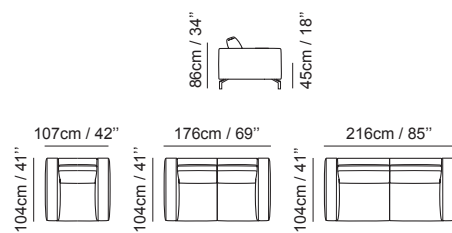

MODULAR ELEMENTS

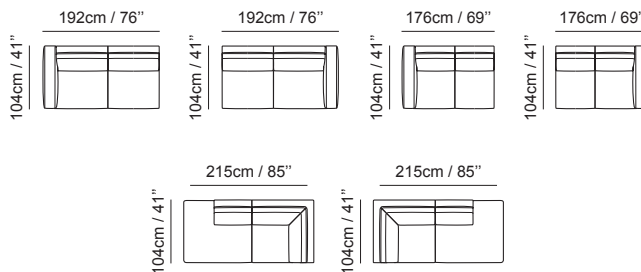

SUGGESTED COMPOSITIONS

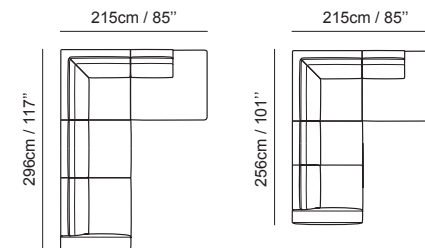



The Herman collection includes sofas in linear and corner versions, with and without chaise longue, as well as ottomans, benches and side tables with metal bases. Each model is exquisitely finished on each side and can be used as a standalone piece. The extreme versatility of the Herman range means the same elements can be reused in countless ways, changing the arrangement or using the elements as standalone pieces to bring dynamic originality to the living area. Upholstery in fabric or exquisite Natuzzi leather. The mix of padding that combines expanded polyurethane, memory foam and Climalight (a special latest generation silicone-treated microfibre) guarantees extraordinary comfort, offering support and lasting good looks. The metal frame is available in a variety of finishes. Side armrests available at two heights: in line with the backrest or lower down, depending on the intended use of the sofa. The grosgrain insert in matching or contrasting colours further enhances the design and personalises the sofa. Optional adjustable cushion that mirrors movements for added comfort also available.

STANDARD VERSIONS

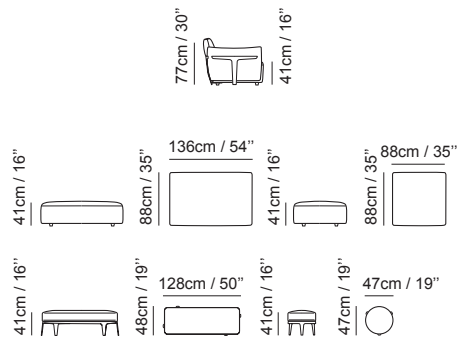

MODULAR ELEMENTS

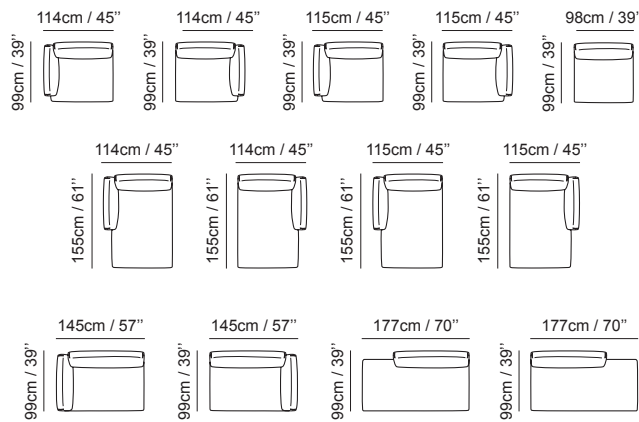

SUGGESTED COMPOSITIONS

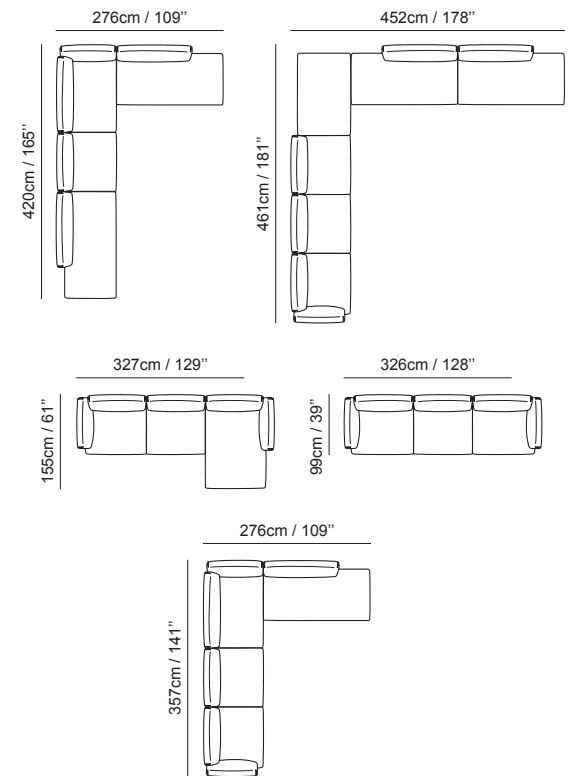



Sofa available in linear or corner versions, with or without recline function. Upholstery in fabric or exquisite Natuzzi leather. The mix of polyurethane and memory foam padding guarantees extraordinary comfort, offering support and lasting good looks. Soft Touch mechanism available for each seat: the recline function is activated with a single touch to adjust the seat, backrest and footrest simultaneously. The relaxation feature is also available with rechargeable batteries to avoid unsightly cables when the sofa is positioned in the middle of a room. The Zerowall space-saving system activates the recline function without the need to position the sofa away from the back wall. The pinched stitching on the armrests and back cushions enhances the design of the model. Feet in scratch-resistant non-slip metal to enable the sofa to be repositioned freely.

STANDARD OR RECLINER VERSIONS

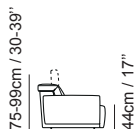

MODULAR ELEMENTS

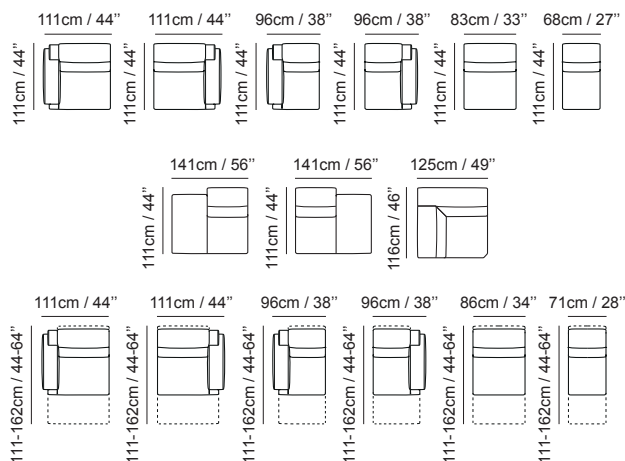

SUGGESTED COMPOSITIONS

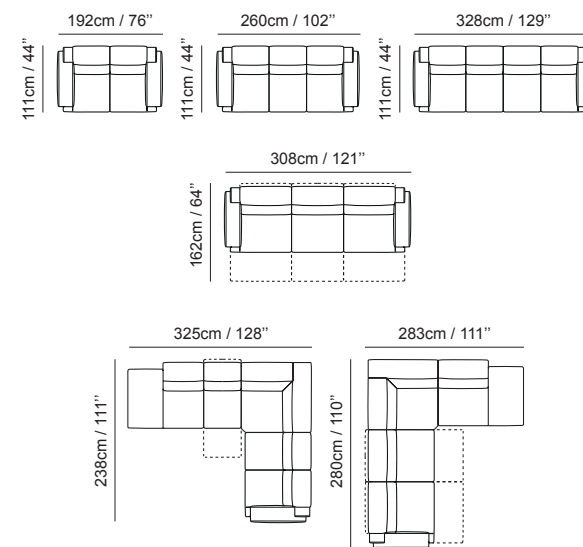



Sofa available in linear or corner versions, with or without table surfaces. Upholstery in fabric or exquisite Natuzzi leather. The mix of padding that combines expanded polyurethane, memory foam and Climalight (a special latest generation silicone-treated microfibre) guarantees extraordinary comfort, offering support and lasting good looks. The sides of each model are also fully upholstered, enabling each element to be repositioned or used as a standalone piece. The lumbar cushions in goose feathers improve the comfort of the seat. The slender metal feet bring lightness and elegance to the model. The teardrop-shaped end table and the wooden surface are available in various finishes (smoked oak, aged walnut and fiddleback briar-root).

STANDARD VERSIONS

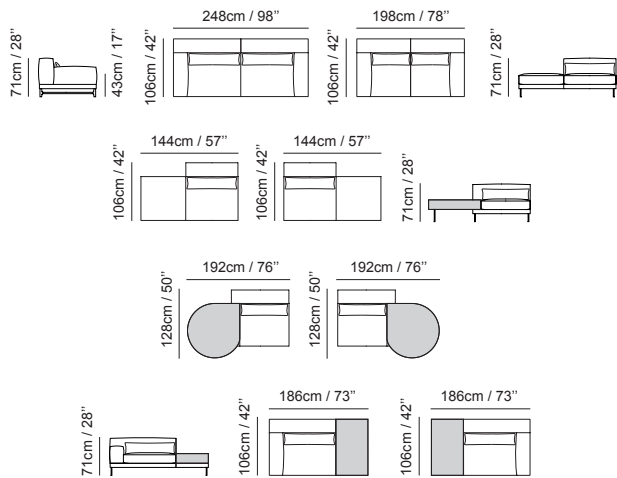

MODULAR ELEMENTS

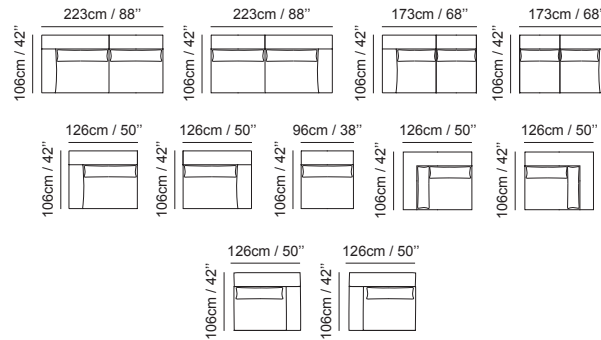

SUGGESTED COMPOSITIONS

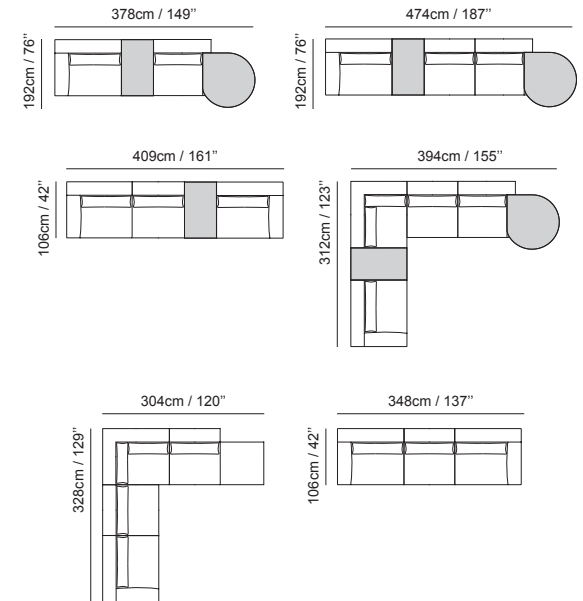



Sofa available in linear, corner and armchair versions. Upholstery in fabric or exquisite Natuzzi leather. The mix of polyurethane, memory foam and feather padding guarantees comfort, support and lasting good looks. The exquisite materials are synonymous with the Natuzzi guarantee of quality.

STANDARD VERSIONS

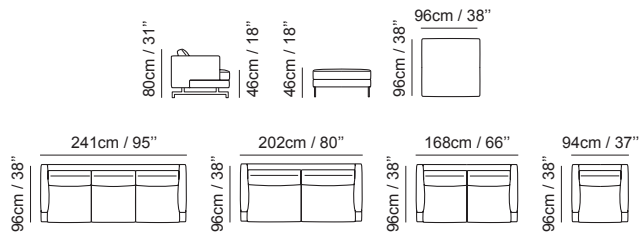

MODULAR ELEMENTS

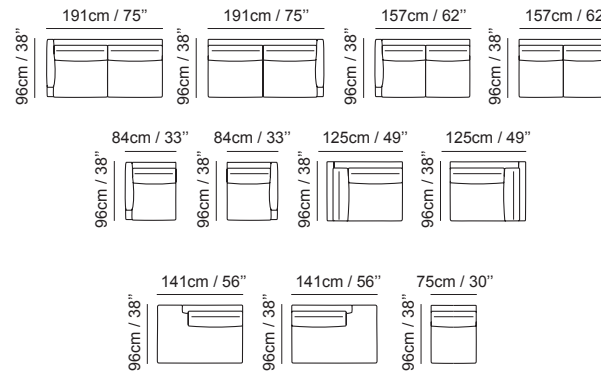

SUGGESTED COMPOSITIONS

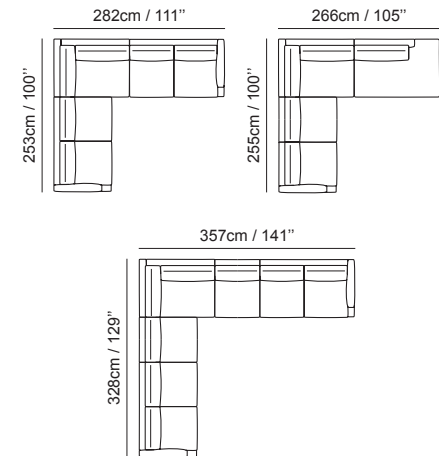



A modern take on the “Chesterfield” sofa with incredibly deep and comfortable armrests and frame. Upholstery in fabric or exquisite Natuzzi leather. The metal feet and open base bring streamlined elegance to the model. Exquisite quilting and the skilful hand-buttoning of the backrest are an expression of the virtuoso craftsmanship which characterises the upholstery. Hand-stitched buttons in leather or fabric, paired with the chosen upholstery. The mix of polyurethane and silicone-treated microfibre padding guarantees extraordinary comfort, support and lasting good looks.

STANDARD VERSIONS

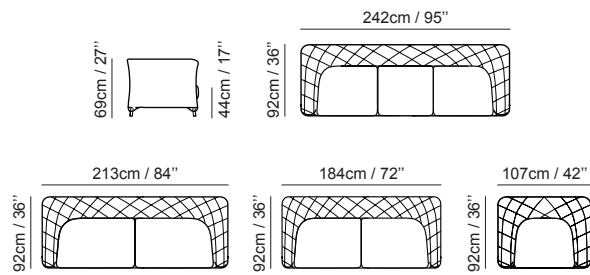



Sofa available in linear or corner versions, with or without chaise longue. Upholstery in removable fabric or exquisite Natuzzi leather. The mix of polyurethane, memory foam and feather padding guarantees extraordinary comfort, offering support and lasting good looks. Generous proportions and refined details emphasise the exquisite manufacturing skill of the model. Metal feet adjustable to two heights to adapt to specific demands of comfort and style. Seat the backrest cushions available in two sizes, padded with soft goose feathers. The sides and cushions feature an exquisite embossed finish, an aesthetic detail which emphasises the refined and artisan look.

STANDARD VERSIONS

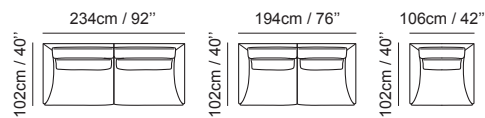

MODULAR ELEMENTS

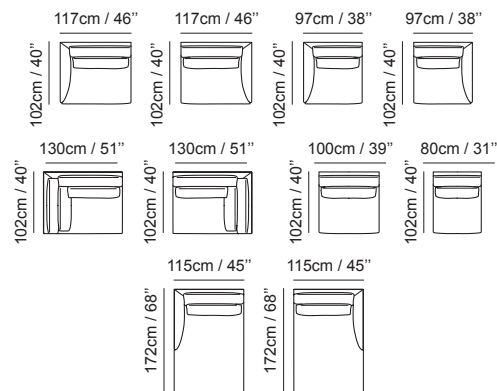

SUGGESTED COMPOSITIONS

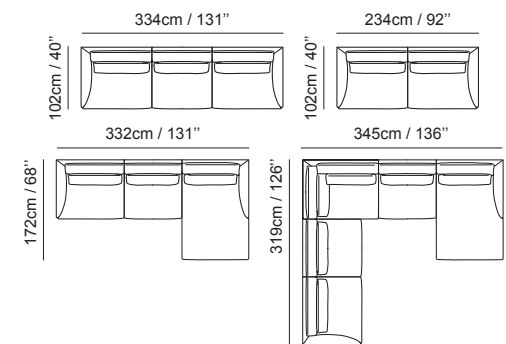



Sofa available in linear versions, with or without chaise longue, and in a two-seater version with single beds. Upholstery in fabric or exquisite Natuzzi leather. Bed function available for the linear and corner versions. Adjustable headrest on each seat. Sprung or Greenplus mattress with antibacterial and hypoallergenic treatment. The ready-bed feature activates the bed function in a single movement. There is a hidden pillow compartment in the rear part of the seat. The smaller size of this model makes it ideal for any space.

STANDARD OR RECLINER VERSIONS

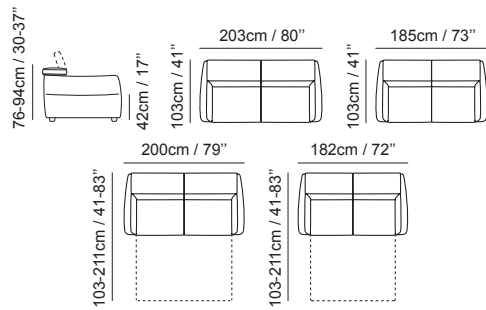

MODULAR ELEMENTS

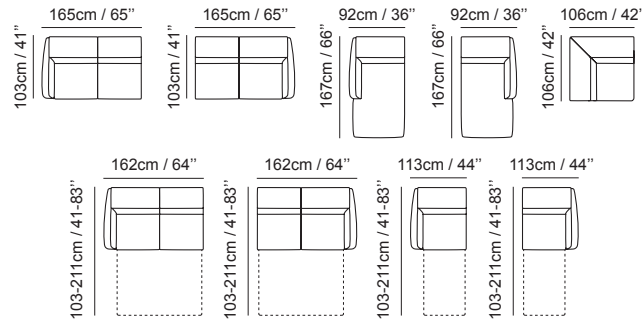

SUGGESTED COMPOSITIONS

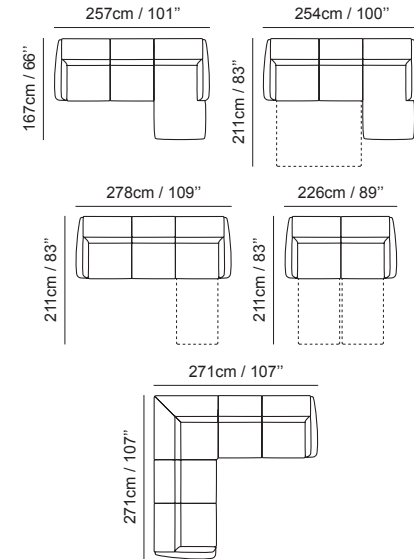



The variety of linear and corner arrangements makes this model suitable for any use in any space. Thanks to the broad range of leather and fabric upholstery, the model can be combined with any lifestyle and choice of furnishing. Soft Touch mechanism available for each seat to activate the recline function with a single touch, adjusting the seat and backrest simultaneously. The Zerowall space-saving system activates the recline function without the need to position the sofa away from the back wall. Metal strip ski feet in various finishes to suit any furnishing style. Skilful hand-stitching and quilting enhance the design.

STANDARD OR RECLINER VERSIONS

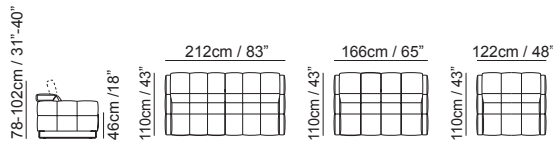

MODULAR ELEMENTS

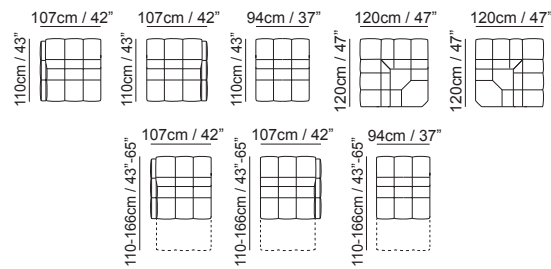

SUGGESTED COMPOSITIONS

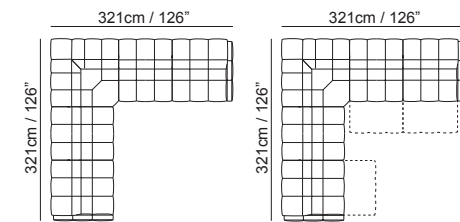



Sofa available in three-seater or two-seater versions. Upholstery in fabric or exquisite Natuzzi leather. The mix of polyurethane, memory foam and feather padding guarantees extraordinary comfort, offering support and lasting good looks. The base and feet in solid wood with metal inserts express the combination of classic and modern styles. Optional trim in contrasting colours to highlight the skilful craftsmanship of the model. The loose cushions filled with feathers are available in a variety of shapes and sizes, offering a promise of total relaxation and bringing a touch of dynamism to the model. Cushions available in different colours and fabrics to those of the sofa.

STANDARD VERSIONS

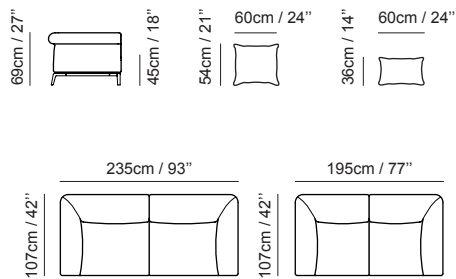



Sofa available as a linear element, corner version with end unit and chaise longue. Upholstery in fabric or exquisite Natuzzi leather. The mix of polyurethane and memory foam padding guarantees extraordinary comfort, offering support and lasting good looks. The headrest and armrests are adjustable for maximum comfort. The open base and metal strip ski feet simplify the design of the model.

STANDARD VERSIONS

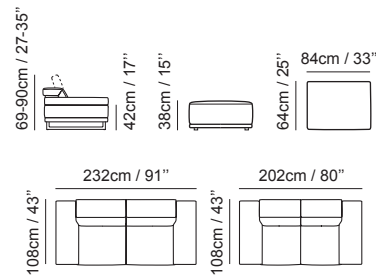

MODULAR ELEMENTS

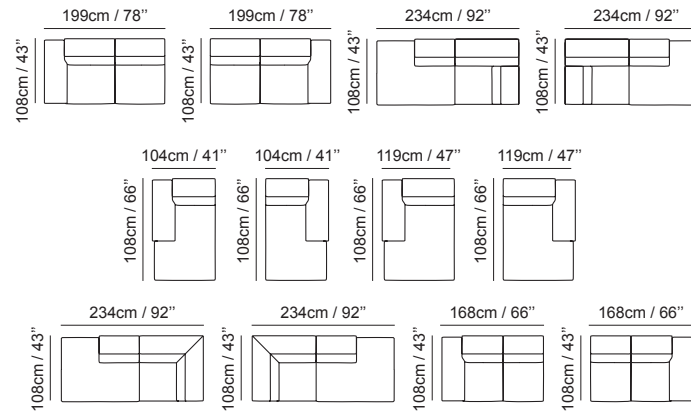

SUGGESTED COMPOSITIONS

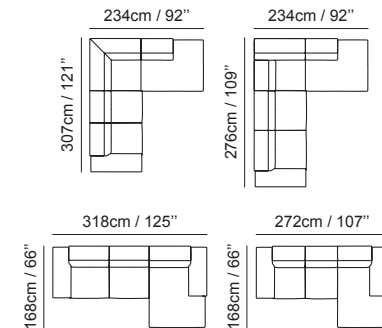



Sofa available in linear or corner versions, with or without chaise longue. Upholstery in fabric or exquisite Natuzzi leather. Individually adjustable headrest on each seat. The high metal feet and open base streamline the model and enable easy cleaning under the sofa. Stitching also available in contrasting colours.

STANDARD VERSIONS

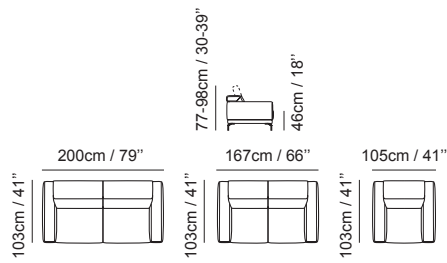

MODULAR ELEMENTS

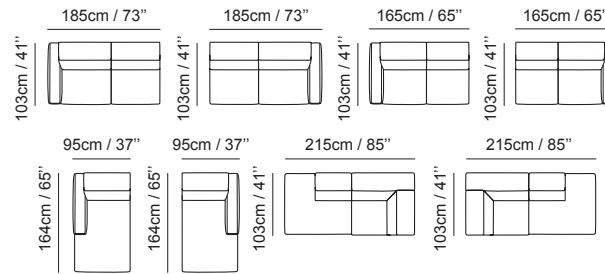

SUGGESTED COMPOSITIONS

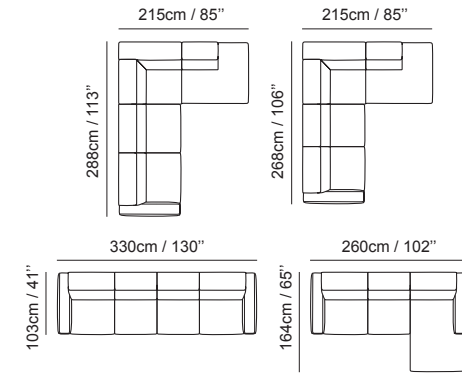



Sofa available in linear and corner versions. Upholstery in exquisite Natuzzi leather. Manually adjustable headrest offering a variety of positions to maximise comfort. The audio system available in the corner version is activated by Bluetooth, USB, AUX and Apple IOS. The audio speakers are built in to the sofa structure. Double stitching also available in contrasting colours. The generous and welcoming seat is characterised by visible stitching which emphasises the skilful hand-stitching of the model. Cushion included in the modular version to enable the corner element to be used as a seat.

STANDARD VERSIONS

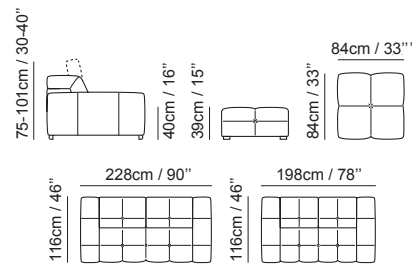

MODULAR ELEMENTS

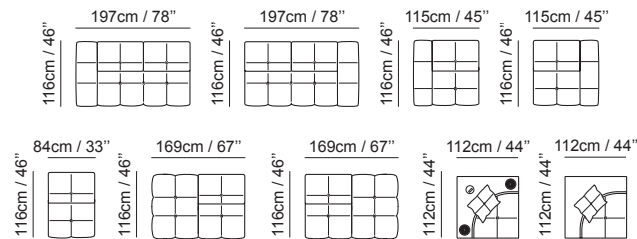

SUGGESTED COMPOSITIONS

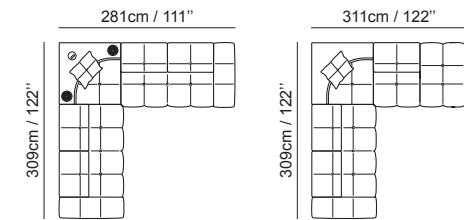



Sofa available in three-seater or two-seater versions. Upholstery in fabric or exquisite Natuzzi leather. The mix of polyurethane, memory foam and feather padding guarantees extraordinary comfort, offering support and lasting good looks. The hand-crafted pinched stitching emphasises the lines and enhances the style of the model. Armrests and feet in solid wood with an oak or walnut veneer with metal inserts available in various finishes. The solid wood foot with metal detail adds a striking and visual solidity. The open base enhances the lightness and linear style of the model.

STANDARD VERSIONS

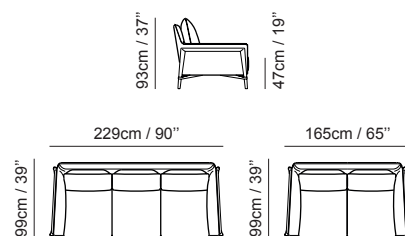



Sofa available in linear, corner and armchair versions. Upholstery in fabric or exquisite Natuzzi leather. The mix of polyurethane, memory foam and feather padding guarantees extraordinary comfort, offering support and lasting good looks.

STANDARD VERSIONS

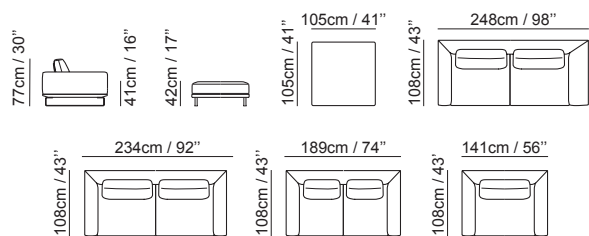

MODULAR ELEMENTS

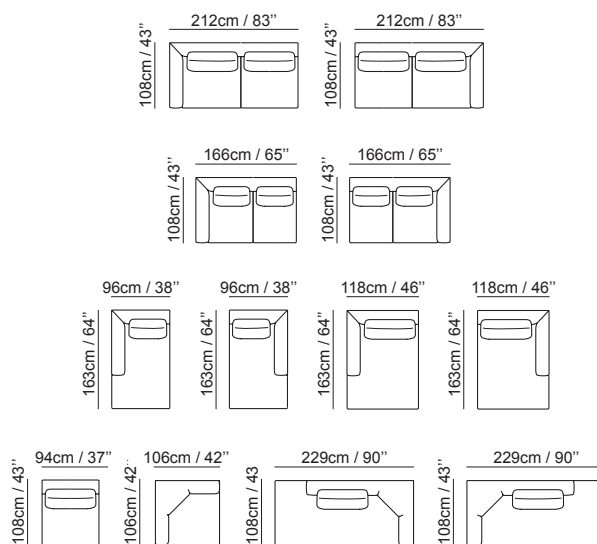

SUGGESTED COMPOSITIONS

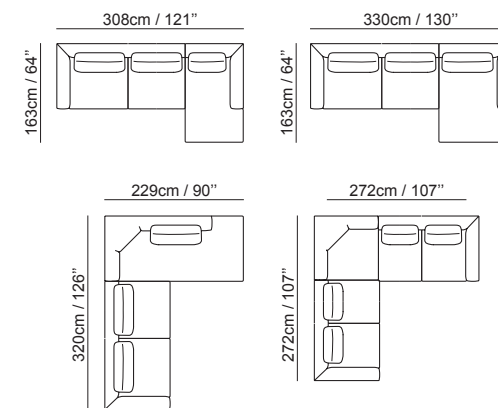



Sofa available in linear versions, with or without chaise longue. Upholstery available in fabric, exquisite Natuzzi leather or a fabric/leather mix. The mix of polyurethane and memory foam padding guarantees extraordinary comfort, offering support and lasting good looks. Metal feet in a geometric and tapered design. The pull-out headrest reflects the tube shape of the decorative armrest cushion. Skilled “moccasin” stitching also available in contrasting colours, which highlights the unique geometry of the armrest. The square micropore cushion increases the comfort of the armrest. The backrest features hand-stitching.

STANDARD VERSIONS

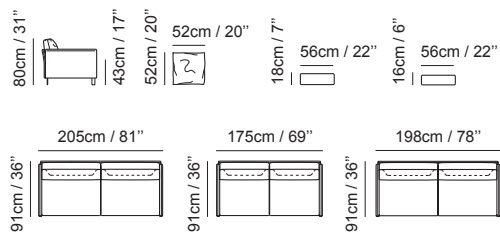

MODULAR ELEMENTS

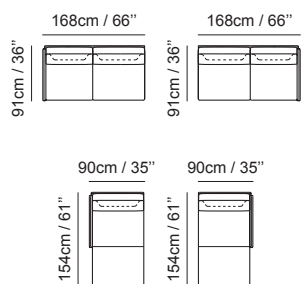

SUGGESTED COMPOSITIONS

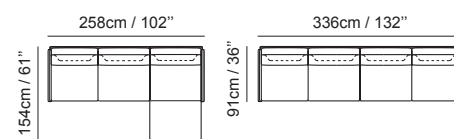



Sofa available in three-seater, two-seater and armchair versions. Upholstery in fabric or exquisite Natuzzi leather. The contemporary design makes it ideal for furnishing urban settings, including small spaces. The open base and high metal feet (available in multiple finishes) streamline the model and enable easy cleaning under the sofa. The zigzag stitching is also available in contrasting colours and emphasises the linear shapes of the model.

STANDARD OR RECLINER VERSIONS

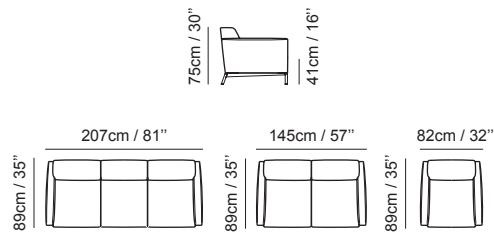



Sofa available in linear and corner versions. Upholstery in fabric or exquisite Natuzzi leather. The mix of polyurethane and memory foam padding guarantees extraordinary comfort, offering support and lasting good looks. The invisible stitching emphasises the clean and elegant lines of the model and the seat and backrest cushions have no seams or stitching. The sofa features a solid wood and metal base synonymous with refinement, harmony and elegance. The wide seats and loose cushions filled with feathers are available in a variety of shapes and sizes, offering a promise of total relaxation and bringing a touch of dynamism to the model (these are also available in different colours and fabrics).

STANDARD VERSIONS

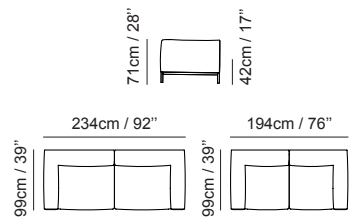

MODULAR ELEMENTS

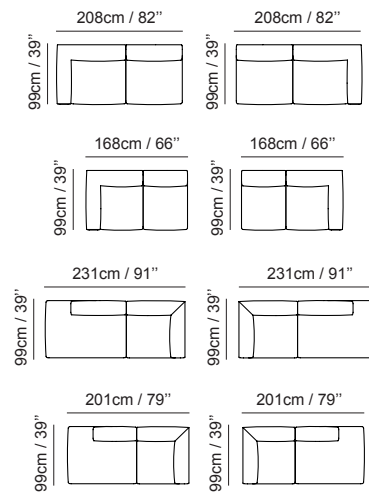

SUGGESTED COMPOSITIONS

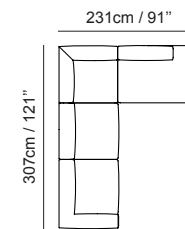



Sofa available in linear, corner and armchair versions, with or without recline function. Upholstery in fabric or exquisite Natuzzi leather. The mix of polyurethane and memory foam padding guarantees extraordinary comfort, support and lasting good looks. The metal feet are available in a variety of finishes. Adjustable headrest on each seat. Soft Touch mechanism available for each seat: the recline function is activated with a single touch to adjust the seat, backrest and footrest simultaneously. The model is also available with the space-saving Zerowall system which activates the recline function without the need to position the sofa away from the back wall. The skilful stitching, also available in contrasting colours, demonstrates Natuzzi's long history of leatherwork.

STANDARD OR RECLINER VERSIONS

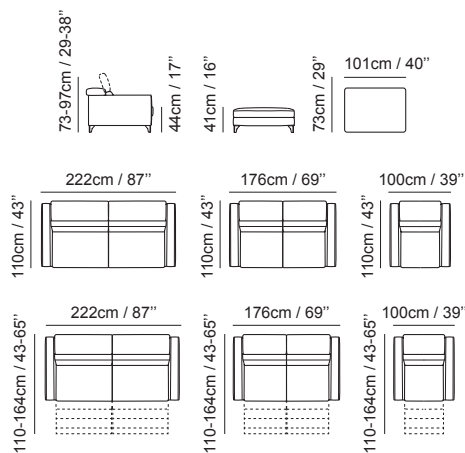

MODULAR ELEMENTS

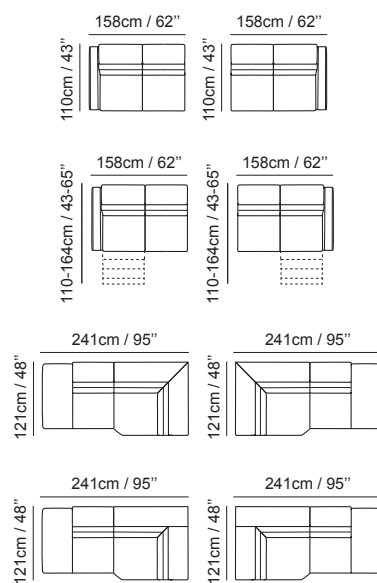

SUGGESTED COMPOSITIONS

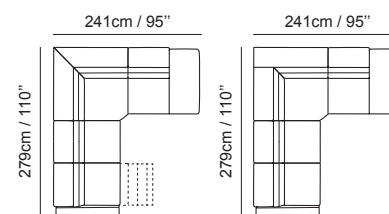



Armchair upholstered in exquisite Natuzzi leather. Feather padding. Wooden feet available in a variety of finishes. Optional trim in contrasting colours. The sofa is complemented by a footrest.

STANDARD VERSIONS

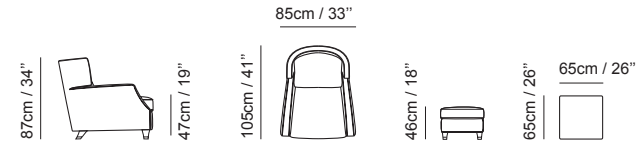

Armchair upholstered in fabric or exquisite Natuzzi leather. Compact size. Characterised by a refined look, enhanced by metal feet embedded in the frame and available in various finishes. The model adapts well to different living spaces such as the living area or bedroom.

STANDARD VERSIONS

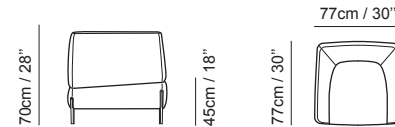

Armchair upholstered in fabric or exquisite Natuzzi leather. Solid wood structure available in a variety of finishes. The model is available with a high or low backrest for optimum personal comfort.

STANDARD VERSIONS

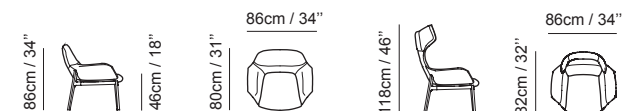



Easy chair upholstered in fabric or exquisite Natuzzi leather. Metal structure. The rear of the backrest and section below the seat are upholstered in leather.

STANDARD VERSIONS

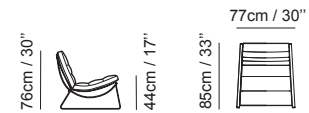

DOLLY page 140



Armchairs available in leather and fabric. The mix of polyurethane and memory foam padding guarantees extraordinary comfort, offering support and lasting good looks. The trim, also available in contrasting colours, runs along the outer edge and emphasises the skilful craftsmanship. The slender metal feet add elegance and lightness.

STANDARD VERSIONS

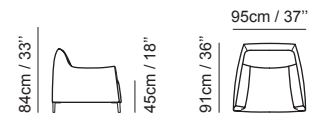

ERA page 144



Chair upholstered in leather. The model is available in different colours.

STANDARD VERSIONS

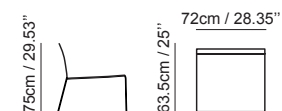



Armchair available in leather and fabric. The mix of expanded polyurethane and Climalight padding guarantees comfort, support, durability and lasting good looks. The grosgrain trim is also available in contrasting colours and emphasises the lines of the model. Electric recline function with an inbuilt rechargeable battery which activates the footrest and backrest separately. The headrest is adjusted manually to obtain the desired position. Wooden frame in various finishes.

STANDARD VERSIONS



Armchair upholstered in fabric or exquisite Natuzzi leather. The optional trim, also available in contrasting colours, outlines the edge of the armchair and emphasises its flowing lines. The metal feet streamline the model.

STANDARD VERSIONS



Armchair upholstered in fabric or exquisite Natuzzi leather. Wide swivel base in metal. The mix of polyurethane, memory foam and feather padding guarantees extraordinary comfort, offering support and lasting good looks.

STANDARD VERSIONS





Armchair upholstered in fabric, exquisite Natuzzi leather or a fabric-leather mix. The model blends design with pure relaxation. The seat features a Memory Foam insert for added comfort and to ensure lasting good looks. The versatile design makes this armchair ideal for the living area or bedroom.

STANDARD VERSIONS

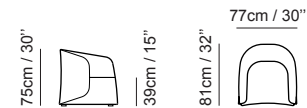

MARLENE pages 138, 139, 198



Armchair upholstered in removable fabric or exquisite Natuzzi leather. Wooden feet. Tall backrest for support and comfort.

STANDARD VERSIONS



NATALIE pages 135, 209



Leather armchair with a wide seat for maximum comfort. The castors of the back feet enable easy movement and characterise the design of the model. Memory Foam padding. Optional trim in contrasting colours.

STANDARD VERSIONS

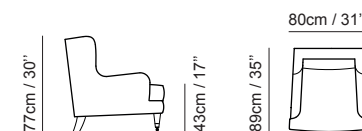



Armchair upholstered in fabric or exquisite Natuzzi leather. The feather padding of the seat enhances the comfort of the model. Metal swivel base. The model is characterised by a high backrest and comfortable seat.

S T A N D A R D V E R S I O N S

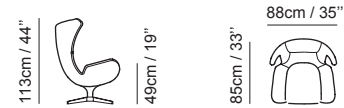

Armchair upholstered in fabric or exquisite Natuzzi leather. Metal feet.

S T A N D A R D V E R S I O N S

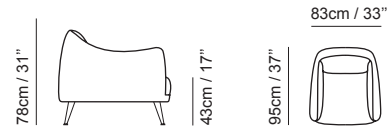

Armchair upholstered in fabric or exquisite Natuzzi leather. Thanks to its simple yet refined lines, this model adapts to any room and any furnishing style. Metal feet in a unique design.

S T A N D A R D V E R S I O N S

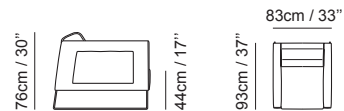



Armchair upholstered in fabric or exquisite Natuzzi leather. Ergonomic shapes and cutting-edge technologies combine to offer an experience of absolute comfort. Re-vive is the only armchair in the world that adapts to any seating position. Curled up, stretched out, crouched, head down...finally, everyone can indulge in complete relaxation, exactly how they like it. The personalisation process begins from the design, aiming to satisfy every stylistic taste: more welcoming, more contemporary, softer, more linear. King or Queen? Choose your ideal seat size for maximum comfort. There is a myriad of colours available, selected after a careful study of international colour trends. The foot of each Re-vive armchair is supported by a base which mirrors its movements. The base is available in a variety of finishes. Optional coordinated footrest also available.

STANDARD VERSIONS QUILTED

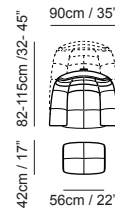
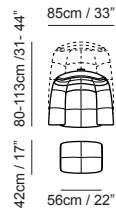

STANDARD VERSIONS LOUNGE

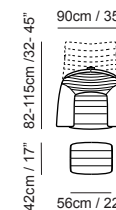
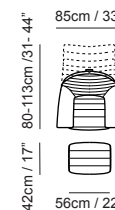

STANDARD VERSIONS WING BACK

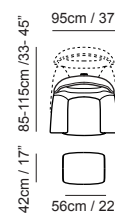
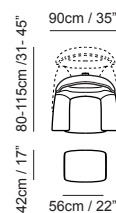

STANDARD VERSIONS CLUB

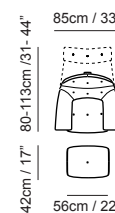



Armchair upholstered in fabric or exquisite Natuzzi leather. Audio system. The speakers are built into the headrest, while the perforations in the upholstery enhance the three-dimensional sound. Swivel base. Footrest.

STANDARD VERSIONS

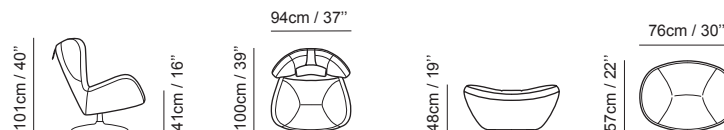

Armchair upholstered in fabric or exquisite Natuzzi leather. The contemporary design makes it ideal for furnishing urban settings, including small spaces. The zigzag stitching is also available in contrasting colours and emphasises the linear shapes of the armchair.

STANDARD VERSIONS

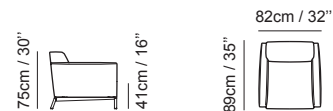

Armchair upholstered in fabric or exquisite Natuzzi leather. Wooden structure. Metal armrests.

STANDARD VERSIONS





Collection of versatile side tables in different shapes, sizes and materials. The varnished metal tubing of the structure is available with a glossy chrome, chestnut or pewter finish. The table tops are available in tempered glass (10mm thick) painted dove-grey, anthracite, white, coffee and cement. Certain versions are available with a top in white Carrara marble, treated with a special sanded and brushed treatment and protected with a special stain and scratch-resistant paint. The tops are also available in wood-veneer MDF in a smoked oak or coffee oak finish, or in stainless steel in a nickel silver finish.

VERSIONS AVAILABLE

Square Centre Table 90cm x 90cm H 34cm - **Rectangular Console Table** 90cm x 27cm H 56cm
Round Centre Table Ø 100cm H 34cm -
Rectangular Centre Table 140cm x 80cm H 34cm / 160cm x 50cm H 34cm
Square Corner Table 45cm x 45cm H 54cm - **Round Corner Table** Ø 45cm H 56cm

CABARET X pages 71, 73, 88



Collection of versatile side tables. The structure is in galvanised metal with a glossy chrome or black chrome finish. The top is in tempered glass (10mm thick) and is available in a tinted or extra white finish.

VERSIONS AVAILABLE

Square Centre Table 105cm x 105cm H 40cm - **Square Corner Table** 60cm x 60cm H 60cm
Round Centre Table Ø 110cm H 40cm

CHOCOLAT pages 47-49



Collection of side tables characterised by a unique geometric shape and the use of exquisite materials. The structure is metal with a pewter finish and is treated with a transparent scratch-resistant protective varnish. The tops are available in veneer MDF with a smoked oak finish, in ivory white porous travertine and Imperial Grey marble with a non-uniform grey background and white veining. The two stone surfaces are treated with water-proofing and stain-resistant treatments.

VERSIONS AVAILABLE

Centre Table 83cm x 101cm H 28cm
Side Table 48cm x 57cm H 50cm

DORIS, GINGER & GRACE pages 16, 139



The Doris, Ginger and Grace side table collection is characterised by the oval, octagonal and scalloped tops in mirrored nickel silver glass. The structure in solid tubular metal features a glossy chrome finish. The base is in stainless steel.

VERSIONS AVAILABLE

Oval 35cm x 50cm H 38cm - **Octagonal** 43cm x 43cm H 53cm
Scalloped 30cm x 41cm H 43cm

HERMAN pages 21, 23, 24, 26, 28, 75, 142, 192, 198



Side table collection characterised by different finishes and a mix of exquisite materials. The metal structure is varnished pewter and finished with a special protective scratch-resistant varnish. The table tops are available in smoked oak wood veneer, coffee satin glass with a fingerprint-free and scratch-resistant finish and Italian Orobic and Calacatta Oro marble protected with a special stain-resistant varnish.

VERSIONS AVAILABLE

Square Centre Table 100cm x 100cm H 27cm - **Round Side Table** Ø 45cm H 34cm / Ø 56cm

IDO pages 35, 36, 38, 42, 43, 51, 78, 80, 95, 107, 108, 145



Side table collection crafted in a carefully selected mix of exquisite materials.

The metal structure is painted pewter with a satin anodised-effect finish. The stainless steel table tops are thin and finished in champagne or black chrome paint with a protective scratch-resistant finish. The tops are also available in 8 cm thick MDF with smoked oak, fiddleback briar-root and American walnut veneer with all-over anthracite matt lacquer. The side table tops are available in Italian Calacatta Oro marble with a lost-wax finish, and dark blue Silver Wave marble with silver veining.

VERSIONS AVAILABLE

Square Centre Table 90cm x 90cm H 39cm - **Round Centre Table** Ø 90cm H 39cm
Round Side Table Ø 42cm H 39cm / Ø 55cm H 55cm - **Square Side Table** Ø 40cm H 47cm



Collection of side tables available in different versions and sizes. The structure is MDF with a smoked oak veneer. The surfaces are available in lacquered MDF with a matt lacquer finish in white, coffee, cement, anthracite and grey. Also available with a drawer with a push and pull soft closing mechanism. Drawer interior in matt lacquer to match the external structure. The drawer fronts are also available in metal with a nickel silver, antique bronze or galvanised black chrome finish.

VERSIONS AVAILABLE

Rectangular Side Table 50cm x 102cm H 50cm **Square Centre Table** - 102cm x 102cm H 38cm



Side tables characterised by geometric shapes and colours. The hidden swivel castors enable easy movement while the open storage containers can also be used as small bookshelves. The tables are crafted in thin (8 mm) but hard-wearing glass. The unique style of the glass helps to create the interplay of different tones and colours. The available finishes are bronze, tint, transparent, blue/purple and yellow/bronze.

VERSIONS AVAILABLE

Square Corner Table 60cm x 60cm H 42cm - **Swivel Bookcase** 60cm x 60cm H 70cm
Rectangular Centre Table 85cm x 125cm H 34cm



A versatile table to be paired with the Long Beach sofa. The metal structure is varnished anthracite. The top in MDF with smoked oak finished wood veneer is treated with a special scratch-resistant varnish.

V E R S I O N S A V A I L A B L E

Rectangular Side Table 35cm x 42cm H 51cm



Collection of versatile side tables characterised by the unique position of the feet which centrally intersect the surface. The feet in tapered metal tubing are available in pewter or black chrome paint finished with a special scratch-resistant varnish. The tops of the side tables are in lacquered MDF in coffee, white, sand, burgundy and rope with a glossy or matt finish. The tops of the centre tables are in MDF finished with a smoked oak or olive walnut veneer.

V E R S I O N S A V A I L A B L E

Round Side Table Ø 38cm H 50cm / Ø 53cm H 60cm - **Rectangular Centre Table** 78cm x 123cm H 38cm
Square Corner Table 63cm x 63cm H 50cm



Collection of side tables characterised by a mix of materials such as wood, metal and marble. The solid wood feet are available in a smoked oak, olive walnut and coffee oak finish. The detail on the feet is metal with a pewter finish. The tops are available in veneered wood featuring the unique wedge design, in a smoked oak, coffee oak or olive walnut finish. The tops are also available in Italian Calacatta Oro marble with a lost-wax finish, and in Dark Emperador marble. The marble surfaces are finished with a transparent and protective water-repellent and scratch-resistant varnish.

V E R S I O N S A V A I L A B L E

Round Corner Table Ø 95cm H 60cm - **Round Centre Table** Ø 120cm H 35cm



Functional and versatile side tables offering constantly changing combinations. The structure and top of the centre table is in MDF with an olive walnut or smoked oak veneer. The structure and top of the side table is in MDF with a white, coffee, sand, rope or burgundy matt lacquer finish.

VERSIONS AVAILABLE

Square Side Table 45cm x 45cm H 44cm - **Rectangular Centre Table** 120cm x 80cm H 34cm

TEMPO pages 40, 44, 52, 62, 64, 83, 86, 118, 119



This collection of side tables is extremely versatile thanks to the variety of easily-combinable versions and materials. The varnished metal structure is in anthracite with a textured finish. The table tops are available in tempered and satin glass (8 mm thick) with a mark and scratch-resistant treatment in a coffee finish, in wood veneer MDF in an coffee oak or smoked oak finish, in stainless steel with a nickel silver finish treated with a silver-plating process which conveys the exquisite warmth of silverware produced by Medieval silversmiths, and in Italian Calacatta Oro marble treated with a water-resistant finish.

VERSIONS AVAILABLE

Rectangular Centre Table 70cm x 148cm H 25cm / 73cm x 118cm H 39cm
Rectangular Side Table 60cm x 105cm H 50cm
Rectangular Rear Side Table Left & Right 59cm x 110cm H 50cm -
Rectangular Side Table 46cm x 56cm H 50cm

ALEGA pages 134, 193



Glass lamp with a transparent base and white lampshade.

VERSIONS AVAILABLE

Table Lamp Ø 45cm H 46cm

ASTRA pages 121, 123, 132, 143



A collection of lamps with hand blown opaline glass lampshades with an external etched finish. Available as a floor lamp, table lamp and abat jour, with a painted steel stand in white and pewter.

VERSIONS AVAILABLE

Floor Lamp Ø 45cm H 165cm - **Table Lamp** Ø 32cm H 58cm

Abat Jour Ø 32cm H 21cm / Ø 45cm H 28cm

ELSA pages 55, 205, 207



Collection of lamps with metal stands and curved and painted metal lampshades. The angles of the stand and lampshade are adjustable. Available as a floor and table lamp in a blue, green and marsala finish.

VERSIONS AVAILABLE

Floor Lamp H 150cm - **Table Lamp** H 59cm

GONG & GONG MINI pages 21, 23



Collection of pendant lamps with light diffuser. The lampshade is in blown glass with a painted or metallic internal finish. Metal ceiling disk varnished in matt white with anodised aluminium cable. Apart from the white version, the top of the lampshade is in transmirror and can be seen through the glass. The bottom part of the lampshade is in transparent glass.

VERSIONS AVAILABLE

Pendant Lamp Ø 30cm X H37.5 - **Mini Pendant Lamp** Ø 13.5cm X H 16.5cm



Lamp with lampshade, stand and circular base in painted steel with a soft-touch finish. Available in a coffee, white and anthracite finish.

V E R S I O N S A V A I L A B L E

Floor Lamp Ø 37cm H 190cm

MUNEGA page 98



White freehand-crafted blown glass lamp. The metal components are painted white. Available in two different sizes.

V E R S I O N S A V A I L A B L E

Table Lamp Ø 20cm H 27cm / Ø 48cm H 55cm

NESSA pages 17, 136



Glass lamp crafted entirely by hand. The transparent strip at the base maximises the light source, while the rest of the body in white glass acts as a light diffuser.

V E R S I O N S A V A I L A B L E

Table Lamp Ø 40cm H 38cm

ONDA pages 50, 92, 101, 103, 145, 186, 187, 188, 202, 210



Collection of lamps with metal stands and lampshades. The patented lampshade is produced with a single mould and is characterised by flowing details which create a delicate interplay of light and shadow. Available as a floor or table lamp, in 2 sizes, in a pewter and essential grey finish with a soft-touch effect.

V E R S I O N S A V A I L A B L E

Floor Lamp Ø 45cm H 168cm - **Table Lamp** Ø 20cm H 40cm / Ø 30cm H 50cm



Lamp with a varnished metal stand and lampshade featuring a circular Plex top for softer light. The essence of the project lies in the balance between the base and the top which seems suspended over the stand. Available in three sizes in a white (with soft-touch varnish), bronze, gold or black chrome finish.

V E R S I O N S A V A I L A B L E

Table Lamp Ø 20cm H 36cm / Ø 28cm H 50cm / Ø 36cm H 64cm



Blue

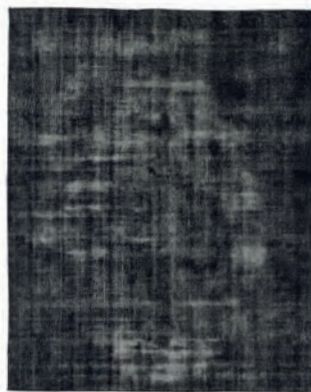

Grey



Brown



Natural

Hand-woven rug, 100% wool. The wool pile is salt-washed to neutralise its original state, then dyed to produce unique and original colour compositions in a vintage effect. The central motif is reminiscent of Nineteenth century tradition while the salt-wash adds a highly contemporary style. Wool is a natural material which enhances the warmth, softness and cushioning of the rug. Shedding is frequent, particularly in the initial period of use, due to the hand-worked knotting and the natural composition of the wool.

V E R S I O N S A V A I L A B L E

360cm x 250cm

CUBE page 104



Rope and charcoal grey

Hand-tufted rug, 100% vegetable silk. Characterised by geometric shapes which unfold and flow into one another in alternating colours, creating cubes in an almost three-dimensional effect. Shedding is frequent, particularly in the initial period of use, due to the hand-worked knotting of the fabric.

V E R S I O N S A V A I L A B L E

170 cm x 240cm / 200cm x 300cm

MARCUS pages 16, 36, 44, 94, 119



Beige



Grey

100% viscose rug, woven. Viscose is an artificial fibre which emulates the shine and soft velvety feel of natural silk. It has a shimmering appearance and an irresistibly light feel. It does not tear or crease easily and can be manipulated with ease, as well as having a high humidity absorbency level. Shedding is frequent, particularly in the initial period of use, due to the hand-worked knotting of the fabric.

V E R S I O N S A V A I L A B L E

200cm x 300cm

OTTAVIO pages 96, 126, 128



Grey



Light grey

Hand-woven rug crafted using the Flatwave technique, 40% wool and 60% viscose. The wool brings softness and lightness, while the viscose gives the surface a bright, shimmering look. The viscose and wool blend creates a very manageable fabric which is resistant to wear, abrasion and creasing, with good colour performance. The combination of the two diverse fibres creates a very captivating and aesthetic texture which is ideal for neutral settings. Shedding is rare thanks to the tight weave and should occur only on initial use.

V E R S I O N S A V A I L A B L E

200cm x 300cm



Grey



Brown

Hand-knotted rug, 100% wool. Wool is a natural material which enhances the warmth, softness and cushioning of the rug. Shedding is frequent, particularly in the initial period of use, due to the hand-worked knotting and the natural composition of the wool.

V E R S I O N S A V A I L A B L E

200cm x 300cm

RIFLESSO pages 113



Ivory



Rope



Smoke



Taupe

100% viscose rug, hand-knotted on a loom using the “Cut and Loop” technique where the strands are knotted and then trimmed unevenly. Viscose is an artificial fibre which emulates the shine and soft velvety feel of natural silk. Its shimmering and delicate effect enhances the shine and shades of the rug in an uneven way, creating a more aged look. It does not tear or crease easily and can be manipulated with ease, as well as having a high humidity absorbency level. Shedding is frequent, particularly in the initial period of use, due to the hand-worked knotting of the fabric.

V E R S I O N S A V A I L A B L E

170cm x 240cm / 200cm x 300cm

RHOMBUS pages 31, 33, 114, 117



Grey

Hand-tufted rug, 100% vegetable silk. The different shades of colour in the Rhombus rug create a delicate interplay of shapes. The material is soft, glossy and silky to the touch, pairing perfectly with any floor to bring extraordinary elegance to the furnishings and décor.

V E R S I O N S A V A I L A B L E

170cm x 240cm / 200cm x 300cm

SETI pages 24, 26, 62, 65, 66, 68, 70, 101, 103



White silver

Hand-knotted rug woven in the traditional Tibetan knotting style. 100% bamboo silk. An alternative to silk produced by silkworms, bamboo silk is a sustainable and renewable natural fibre derived from bamboo plants. It offers the same softness, shine and velvety feel as true silk. The texture is emphasised by neutral and relaxing colours which seem to shimmer in the light. The result is an elegant, simple, glossy and natural rug. Shedding is frequent, particularly in the initial period of use, due to the hand-worked knotting of the fabric.

V E R S I O N S A V A I L A B L E

200cm x 300cm

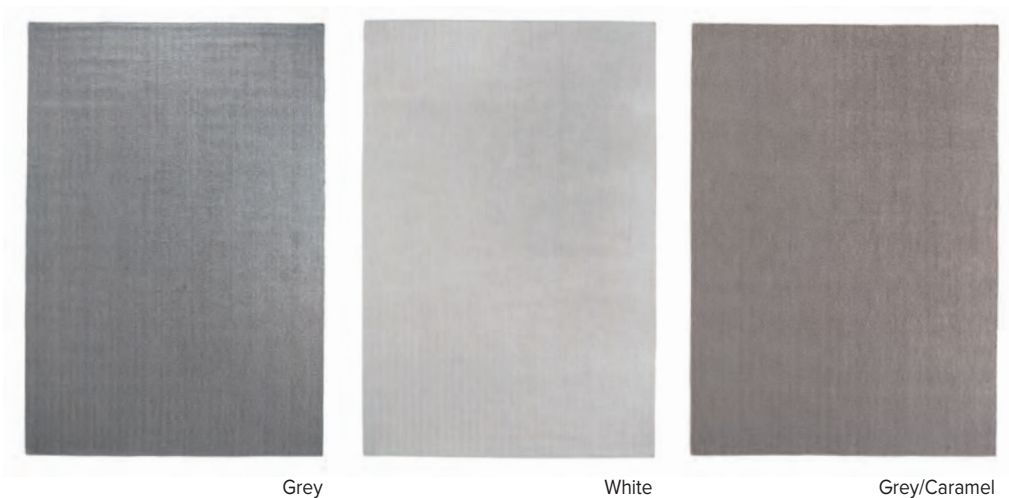

Grey

White

Grey/Caramel

35% wool and 65% viscose rug, hand-knotted on a loom. The wool brings softness and lightness, while the viscose gives the surface a bright, shimmering look. The viscose and wool blend creates a very manageable fabric which is resistant to wear, abrasion and creasing, with good colour performance. The combination of the two diverse fibres creates a very captivating and aesthetic texture which is ideal for neutral settings. Shedding is frequent, particularly in the initial period of use, due to the hand-worked knotting of the fabric.

V E R S I O N S A V A I L A B L E

200cm x 300cm



Wall unit system with a wood veneer MDF frame, composed of modular elements, open cabinets and door cabinets available in different sizes. The thickness of the structure (6 cm) is obtained thanks to a special technique which adds greater solidity and precision. The structure is available in a smoked oak veneer with open-pore finish or in glossy or matt lacquer in white, coffee, cement, burgundy and anthracite. The wooden drawers and door cabinets are available in smoked oak or glossy or matt lacquer, with different opening mechanisms: doors with push and pull mechanisms, soft closing drawers and drop-down doors. The doors are available in special metallic finishes: nickel silver stainless steel, black chrome and ancient bronze. The storage compartments can be arranged in various ways and are available in two depths: 38 cm and 43 cm. An adjustable TV panel is also available. The glossy and matt lacquers are obtained with a solvent-free water-based varnish. Each individual element is tested for resistance to marks, scratches and light and complies with REACH regulations. The feet can be adjusted during assembly.

SUGGESTED COMPOSITIONS



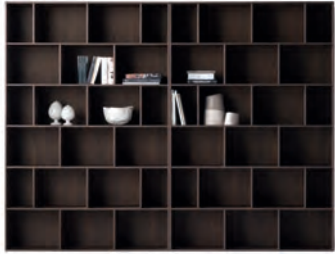

A modular and versatile system of wall units, characterised by modular elements which can be used to create numerous compositions. The structure is MDF with a wood veneer. Available in smoked oak and coffee oak wood, or in glossy or matt lacquer in coffee and grey. The lacquers are obtained with a solvent-free water-based varnish. The storage cubes and drawers are available with different opening mechanisms: push and pull mechanism doors, soft closing drawers, drop-down doors. Each individual element of the wall unit is tested for resistance to marks, scratches and light and complies with REACH regulations.

SUGGESTED COMPOSITIONS

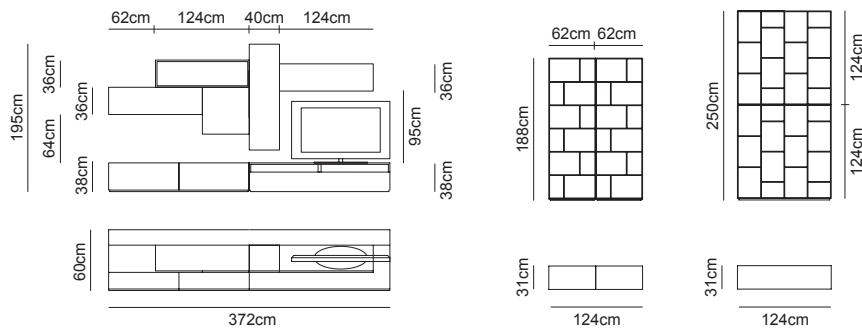



Free-standing bookcase in wood veneer MDF, composed of modular panels connected by supporting shelves. Structure available in a variety of finishes: olive walnut, smoked oak and coffee oak, with tempered glass shelves (12 mm thick) available in three colours: extra-white, tinted and bronze. Also available in two special woods with lacquered shelves: fiddleback briar-root and American walnut. The bookcase is also available with the structure and shelves fully lacquered in coffee, grey, anthracite and burgundy matt finishes. The feet can be adjusted during assembly.

SUGGESTED COMPOSITIONS

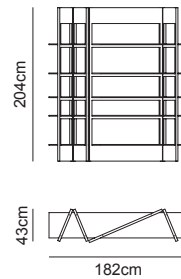

SUGGESTED COMPOSITIONS

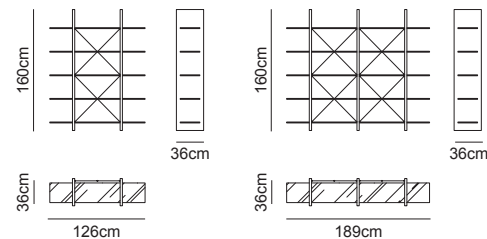

Free-standing bookcase with an open-pore stained oak veneer MDF available in white, coffee and smoked oak finishes. The shelves are in tempered glass (12 mm thick). The supporting panels are finished with a scratch and abrasion-resistant varnish. The steel cables add a unique aesthetic element as well as supporting the structure. The feet can be adjusted during assembly.



Available in a round, square and rectangular (even extendable) version which fits easily into any surrounds. Top in veneered wood with different wood patterning: in the round and square version, the top has been split into segments, creating an intricate geometric design. Frame in solid ash dyed in the colors available. Top in veneered wood available in various finishes. In the extendable version, the table comes with two 40 cm leaves, meaning it can be used for multiple purposes and making it highly versatile.

VERSIONS AVAILABLE

Round Fixed Table 160cm H 75cm - **Fixed Square Table** 135cm x 135cm H 75cm
Extendable Rectangular Table 180 / 260cm x 100cm H 75cm



Fixed or extensible table with anthracite gray metal frame and ultra-clear or tinted tempered glass top. The table comes with an anodized aluminum mechanism that allows for extending the table with two extensions measuring 50 cm each. Tempered glass top with polished ground edges. Glass top resting on stainless steel staves.

VERSIONS AVAILABLE

Extendable Rectangular Table 180 / 280cm x 100cm H 72cm



Fixed table with structure and top made of MDF wood veneer in coffee oak, smoked oak and olive walnut finishes. The top is varnished with a scratch-proof coating. The base offers an interesting mix of wood/lacquer combinations that characterises its design. The aesthetics of the wooden top are embellished by a unique interplay of contrasting lines. Details like these ensure that the quality of the materials and the craftsmanship can be fully appreciated.

VERSIONS AVAILABLE

Fixed Rectangular Table 100cm x 180cm H 74cm

HEX pages 45, 178



Table with a solid wood trapezium base in a sculpted design, available in olive walnut and smoked oak finishes. Top in 12 mm thick extra-clear tempered glass with a bevelled silver edge. The table demonstrates a particularly close attention to detail and artisan craftsmanship according to the best traditions of skilled cabinet-making. The glass top is supported by stainless steel plates.

VERSIONS AVAILABLE

Hexagonal 262cm x 121cm H 74cm

LEGGERO pages 170-171



Fixed or extendable table with solid wood veneered feet available in the fiddleback briar-root, aged American walnut, smoked oak, coffee oak and olive walnut finishes. The inner section of the foot is in matt lacquer to characterise the design. The table top is available in veneered wood in a range of finishes from the pattern book. The table also features a lateral opening mechanism in anodised aluminium that extends the surface by 60 cm.

VERSIONS AVAILABLE

Fixed Rectangular Table 180cm x 90cm H 75cm -
Extendable Rectangular Table 180 / 240cm x 90cm H 75cm

OMEGA pages 118, 121



Fixed and extendable table. The top is elegantly supported by a metal structure varnished in a textured coffee finish. The top is in veneer MDF and is available in the canaletto walnut, smoked oak and coffee oak finishes. The table also features a lateral opening mechanism in anodised aluminium that extends the surface by 60 cm. The desk is available with a lacquered top in coffee, grey and rope, or in Dark Emperador and Calacatta Oro marble.



Fixed table-sculpture with a laser-cut metal base characterised by a special hot-dip galvanizing process which ensures durability and resistance against rust. The metal is treated with a chrome-plating process which adds a unique shine. The tempered glass top features an extra-clear finish (15 mm thick).

V E R S I O N S A V A I L A B L E

Round Fixed Table 160cm H 73cm - **Rectangular Fixed Table** 120cm x 250cm H 73cm



Table with feet and sides in solid European oak and Italian walnut, available in the smoked oak, grey oak and olive walnut finishes. The supporting structure is in varnished steel. The scratch-resistant top in tempered glass features an etched effect and screen-printed back and is available in a milk white, coffee or rope finish. The finishes are applied with the traditional cloth-dye method and are finished with a protective acrylic varnish.

V E R S I O N S A V A I L A B L E

Fixed Rectangular Table 200cm x 100cm H 74cm - **Fixed Square Table** 140cm x 140cm H 74cm

AMBRA page 165



Seat available with or without armrests. The metal structure is completely padded and upholstered. The seat is padded in expanded polyurethane and composed of elastic belts for absolute comfort. Available in leather and fabric in various colours.

VERSIONS AVAILABLE

With Armrests 67cm x 64cm H 85cm - **Without Armrests** 55cm x 63cm H 85cm

BRERA page 176



Seat available with or without armrests. The structure is in solid ash finished in a coffee oak or smoked oak stain, or in solid walnut with an olive walnut stain. The backrest is composed of curved beech plywood in a coffee oak, smoked oak or olive walnut stain. The upholstered seat is padded with expanded polyurethane. The version with the armrests is enhanced by an elegant plate in polished steel. Available in various colours of leather.

VERSIONS AVAILABLE

With Armrests 56cm x 55cm H 80cm - **Without Armrests** 52cm x 50cm H 80cm

LISA page 171



Seat available with or without armrests. The structure is in solid ash finished in a coffee oak or smoked oak stain, or in solid walnut with an olive walnut stain, or in matt paint in two colours. The backrest is composed of curved plywood in a coffee oak, smoked oak or olive walnut stain. The seat is padded with expanded polyurethane. Available in leather and fabric in various colours.

VERSIONS AVAILABLE

With Armrests 57cm x 55cm H 80cm - **Without Armrests** 50cm x 55cm H 85cm



Small armchair with a completely padded and upholstered structure. The seat is padded with expanded polyurethane. Available in leather and fabric in various colours.

V E R S I O N S A V A I L A B L E

With Armrests 63cm x 66cm H 78cm

SIGMA pages 168, 169, 181, 182, 183



Seat available with or without armrests. The structure is metal. The seat and backrest are padded with expanded polyurethane. Available in leather and fabric in various colours.

V E R S I O N S A V A I L A B L E

Without Armrests 49cm x 55cm H 83cm

SONATA page 167



Seat available with or without armrests. The structure is in solid oak finished in a coffee or smoked stain, or in solid walnut with an olive walnut stain. The seat and backrest are padded with expanded polyurethane. Available in leather and fabric in various colours.

V E R S I O N S A V A I L A B L E

With Armrests 63cm x 62cm H 82cm - **Without Armrests** 50cm x 62cm H 82cm

ACCADEMIA pages 61, 100, 165



Units available as sideboards and buffet cabinets for the dining room. The solid geometric structure features a wood veneer in the coffee oak, smoked oak and olive walnut finishes or in glossy rock and glossy anthracite lacquer. The metal base is painted in pewter. The storage units can be closed or open, and the shelves are in extra-clear tempered glass. The open cabinets are available in various matt finishes. The doors are hinged and the drawers feature a soft closing mechanism.

VERSIONS AVAILABLE

Buffet Cabinet 200cm x 43cm H 150cm - **Sideboard** 220cm x 46cm H 80cm

FORTUNA pages 47, 175



The structure and legs of the sideboard are in solid European oak and Italian walnut, available in the coffee oak, smoked oak and olive walnut finishes. The wood finish of the external surfaces is obtained through a skilful cloth-dying process and finished with a protective varnish. The interiors are lacquered matt to match the exterior: coffee for the smoked oak and olive walnut finishes, and grey for the grey oak finish. The doors are hinged and the drawers feature a soft closing mechanism. The door cabinet features internal shelves in extra-clear tempered glass. The top is in etched scratch and fingerprint-free glass, the back is screen-printed and is available in a milk white, coffee or rope finish.

VERSIONS AVAILABLE

Sideboard 220cm x 50cm H 72cm

IDO page 63



The sideboard features a metal base varnished pewter. The structure is in wooden veneer and is available in smoked oak, grey fiddleback briar-root and aged American walnut. The storage units are open or feature drop-down doors.

VERSIONS AVAILABLE

Sideboard 150cm x 37cm H 65cm



Upholstered bed available in various sizes, with or without mattress. Upholstery in fabric or exquisite Natuzzi leather. Fully padded and upholstered headboard and sides. The tall feet in lacquered metal add lightness to the design and enable easy cleaning of the floor. The rear of the headboard is a single piece and is entirely padded. Curved headboard and skilful stitching bring elegance and refinement to the model.

STANDARD VERSIONS

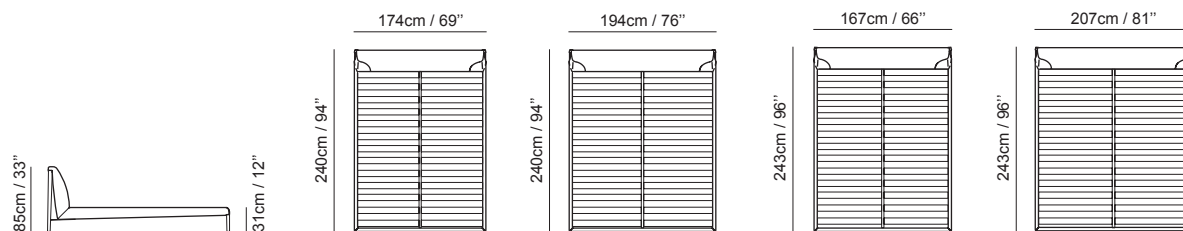



Upholstered bed available in various sizes with or without mattress. Upholstery in fabric or exquisite Natuzzi leather. Headboard with skilful quilting and buttoning detail give the bed its luxurious character. The metal feet in anthracite bring slenderness to the design. The open base enables easy cleaning under the bed.

STANDARD VERSIONS

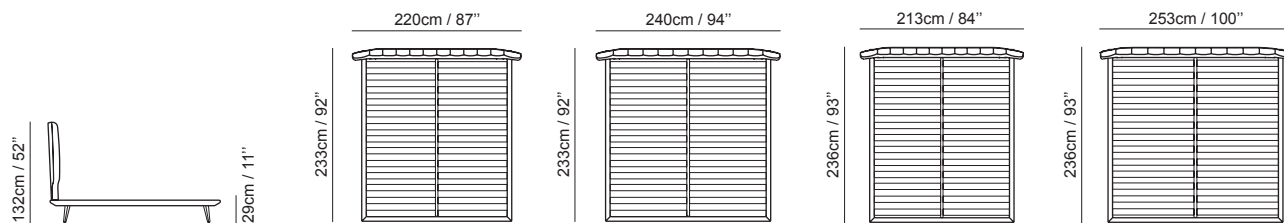



Upholstered bed with or without storage compartment available in various sizes with or without mattress. Upholstery in removable fabric or exquisite Natuzzi leather. The headboard is padded with feathers and polyurethane. Metal feet at the corners add stability and aesthetic value to the structure. The opening mechanism to access the storage compartment offers two possible positions: the first enables you to make the bed without the need to bend down, while the second lets you effortlessly store objects and linen anywhere in the compartment.

STANDARD VERSIONS

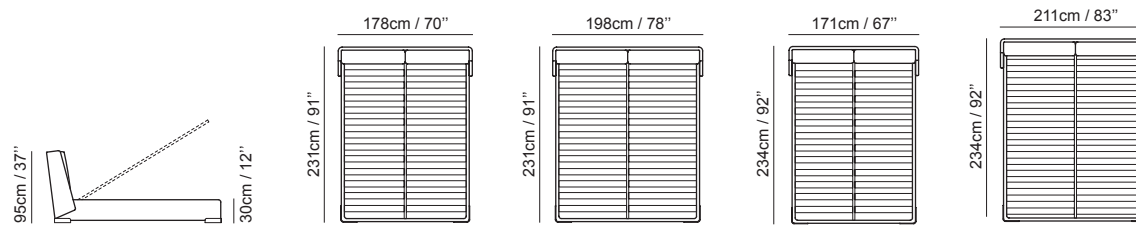



Upholstered bed with and without storage compartment available in various sizes with and without mattress. Upholstery in fabric or exquisite Natuzzi leather. Fully padded headboard and base. The opening mechanism to access the storage compartment offers two possible positions: the first enables you to make the bed without the need to bend down, while the second lets you effortlessly store objects and linen anywhere in the compartment.

STANDARD VERSIONS

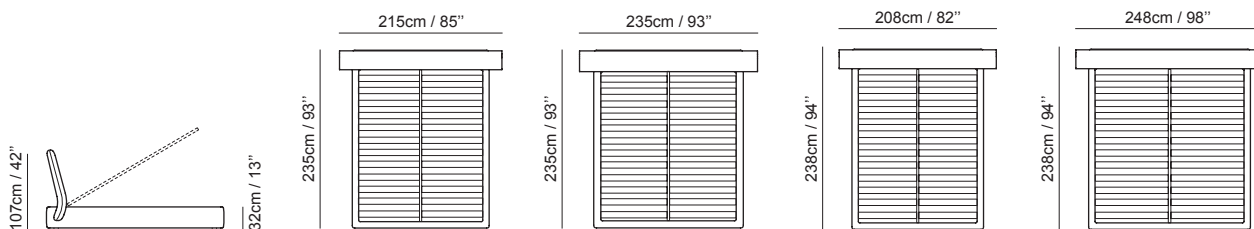



Upholstered bed available in 4 sizes. Upholstery in removable fabric or exquisite Natuzzi leather. Fully padded headboard and base. The trim detail which runs along the outer edge of the bed evokes the soft shapes of a pillow. The open base enables easy cleaning under the bed.

STANDARD VERSIONS

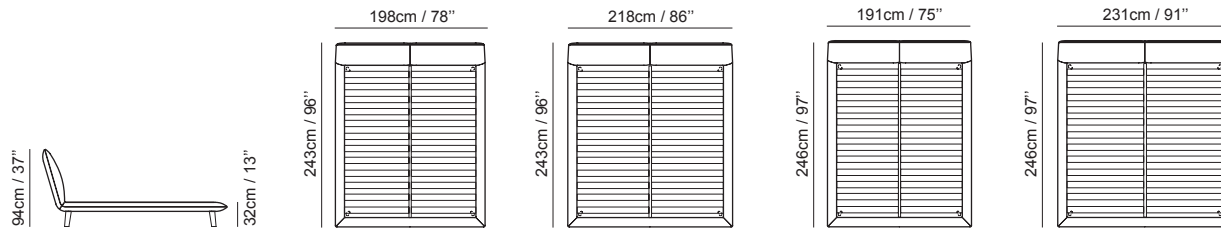

SVEVO pages 200-203



Upholstered bed available in various sizes with or without mattress. Upholstery in removable fabric or exquisite Natuzzi leather. Fully padded headboard for maximum comfort. The solid wood foot with metal detail adds a striking and visual solidity. The open base enhances the lightness and linear style.

STANDARD VERSIONS

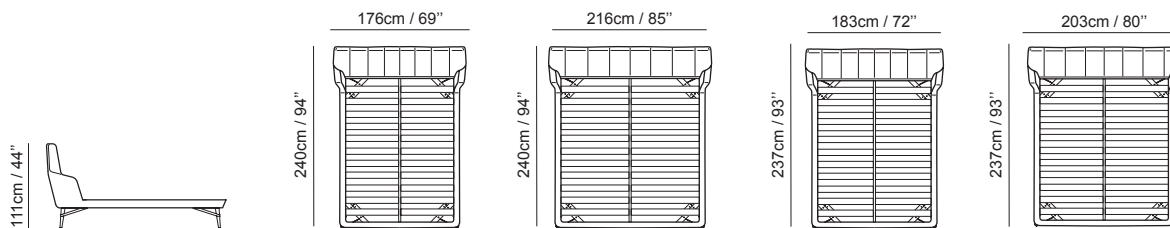



Upholstered bed available in various sizes, with or without mattress. Upholstery in fabric or exquisite Natuzzi leather. The headboard can be manually adjusted to adapt perfectly and comfortably to your desired position, making the bed the perfect place to read and work. The rear of the headboard features useful storage compartments to store pillows, blankets or sheets.

STANDARD VERSIONS

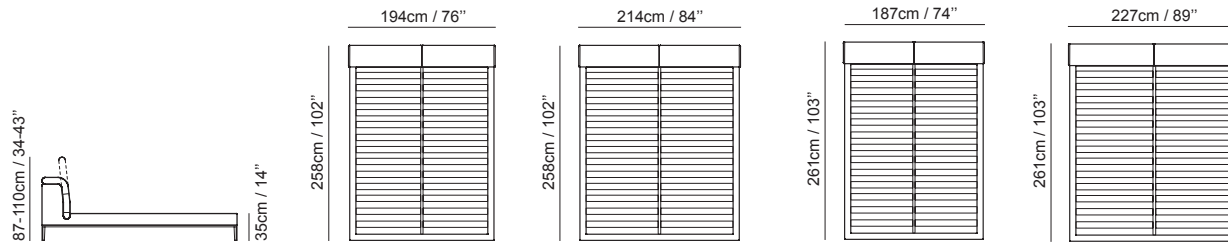



A furniture collection for the bedroom. The base is metal with a structure lacquered in matt coffee. The lacquered metal drawer handles match the colour of the structure. The line of the feet is an integral part of the structure. The interiors are lacquered and the drawers feature a soft closing mechanism. The top is available in matt coffee lacquer or combined with smoked oak.

VERSIONS AVAILABLE

Chest of Drawers 190cm x 55cm H 65cm - **Bedside Table** 60cm x 50cm H 40cm



A furniture collection for the bedroom. The base is metal. The structure is finished in matt lacquer and is available in white, sand, dove-grey, beige, grey, blue and coffee. The drawers are fully lacquered inside and out, in tones to match the external finish. The drawers also feature a soft closing mechanism. Also available as a TV and sideboard unit.

VERSIONS AVAILABLE

Chest of Drawers 160/102cm x 50cm H 70cm - **Bedside Table** 60cm x 50cm H 40cm

TV Unit 150cm x 50cm H40cm - **Sideboard** 180cm x 50cm H55cm



A furniture collection for the bedroom. The base is solid wood and is available in canaletto walnut and smoked oak. The wooden structure is available in the canaletto walnut and smoked oak finishes. The top is available in canaletto walnut, smoked oak, Calacatta Oro marble and Dark Emperador marble. The drawers are fully lacquered inside and out, in tones to match the external finish. The drawers also feature a soft closing mechanism.

VERSIONS AVAILABLE

Chest of Drawers 220cm x 53cm H 75cm / 160cm x 53cm H80cm - **Bedside Table** 65cm x 45cm H 41cm



A furniture collection for the bedroom. The feet are solid wood available in walnut or oak in the smoked finish. The storage unit is in matt lacquer available in matt rope and grey. The tops of the chest of drawers and bedside table are satin glass lacquered in a colour to match the structure.

VERSIONS AVAILABLE

Chest of Drawers 200cm x 55cm H 77cm - **Bedside Table** 78cm x 48cm H 50cm

IN THE WORLD

THE AMERICAS

BRAZIL

SÃO PAULO
Alameda Gabriel Monteiro
Da Silva, 903
01441-000

COLOMBIA

BOGOTA
Carrera 15 Nro. 9871
57-1-4251540

DOMINICAN REPUBLIC

SANTO DOMINGO
Max Henriquez Ureña
Entre Lincoln y Frdco Geraldino 61
809 5650916

MEXICO

MEXICO CITY
Altavista 68, Col. San Angel
55 5550-7002

SAN PEDRO GARZA GARCIA

Calzada del Valle 275 Ote.
Col. Del Valle
81 8335-4000

ZAPOPAN

Boulevard Puerta de Hierro 4965
Local 403
Fracc. Plaza Andares
33 3611-1664

PANAMA

PANAMA
Display Plaza 10, Via Brasil
507 265-1100

PHILIPPINES

TAGUIG CITY
2nd floor, Mos Design Bldg - B2
Bonifacio High Street Fort,
00632-856-7915

USA

BOCA RATON
6001 N Federal Hwy
561 826-8437

FORT LAUDERDALE
2568 E Sunrise Blvd
954 561-6999

MIAMI

3818 N Miami Ave
786 580-5122

NAPLES

3980 Tamiami Trail N
239 529-3397

NEW YORK

105 Madison Avenue
212 346-9760

ORLANDO

4094 Millenia Blvd
407 355-7879

PARAMUS

776 Route 17 North, 2B
201 445.9100

PHILADELPHIA

321 South Street
215 515.3398

PINECREST

9121 South Dixie Hwy
305 381-0298

WEST PALM BEACH

CityPlace,
701 S Rosemary Ave

VENEZUELA

CARACAS
Avenida Principal
De Los Naranjos.
Centro Comercial Casa Mall,
Local G1-Nivel Galeria. Naranjos
0212 214 70 02

ASIA

CHINA

BEIJING
Room 1032, 1st Floor, Easy Home,
No. 1 Yuan Da Road,
Hai Dian District
010-88873532

BEIJING

Room 1-111, 1st Floor, Easy Home,
No.27 Jia, West 3rd Ring
South Road, Feng Tai District
010-63708202

BEIJING

Room 3-06, 3rd Floor, No. 5
International Pavilion,
Easy Home, No.65, North 4th Ring
East Road, Chao Yang District
010-84629030

BEIJING

Room 8-1-003, No. 8 Pavilion, Easy
Home, No. 106 Da Yang Fang Road,
Chao Yang District
010-67322570

BEIJING

Room A8128, 1st Floor, Red Star,
No.193, Middle East 4th Ring Road,
Chao Yang District
010-87951511

CHANGCHUN

Room 28/28A, 3rd Floor, District E,
Building A, Sun City,
No. 772 Liao Ning Road
0431-89365366

CHENGDU

1st Floor, Fu Sen Mei Furniture Mall,
No. 18 Sheng He Er Road,
Gao Xin District
028-61559167

CHENGDU

1st Floor, Import Pavilion, Fu Sen Mei
Furniture Mall, No. 68 Jiang Jun Road,
Cheng Hua District
028-80580330

CHONGQING

1st Floor, Easy Home, Jin Yuan Road, Jiang
Bei District
18680755689

CHONGQING

1st Floor, Red Star,
No.888 Xin Nan Road,
Yu Bei District
18723262519

DALIAN

Room 1-1-011, No. 1 Pavilion, Easy Home,
No. 71 B, Xi Nan Road,
Gan Jing Zi District
0411-39689310

FUZHOU

1st Floor, No. 1 Internation Pavilion,
Easy Home, Intersection of Middle Ba Yi
Qi Road and Qun Zhong Road,
Tai Jiang District
0591-88235380

GUANGZHOU

Room A110, 1st Floor, Pavilioin A,
JSWB Furniture Center, Ying Bin Road,
Fan Yu District
020-84560506

<p>GUIYANG Room B1-8172, 8193, 8195, 8196, 2nd Floor, Red Star, No. 10 You Zha St., Nan Ming District 0851-85500867</p>	<p>KUNMING 1st Floor, Red Star, No. 318 Guangfu Road 18669012090</p>	<p>SHANGHAI Room A060-063, 1st Floor, Moon Star Home Furnishing Square, No. 168 Ao Men Road 021-62481357</p>	<p>TANGSHAN 1st Floor, Chang Ji Furnishing Mall, Intersection of North Long Ze Road and East Long Hua Avenue 0315-6710826</p>	<p>HONG KONG HONG KONG Shop 3-4, G/F Horizon Plaza, 2 Lee Wing Street, Ap Lei Chau +852 23201032</p>
<p>HAERBIN Room 101, 1st Floor, Moon Star Home Furnishing, No. 66 Shang Hai St., Dao Li District 0451-87639120</p>	<p>LANZHOU 1st Floor, Wan Jia Home Furniture Mall, Tian Shui Road 0931-8517569</p>	<p>SHANGHAI Room A107-207, Wending Living Style Plaza, No. 258 Wen Ding Road 021-64416867</p>	<p>TIANJIN Room A001, 1st Floor, Jiayi Home Furnishing Exhibition Center, No. 16 You Yi Road, He Xi District 022-88370368</p>	<p>INDIA BANGALORE 4/1, GF, Bellary Road, Opp. Palace Grounds, Sadashivnagar, +91 80 23617171/ 23611415 +91 9902809999</p>
<p>HANGZHOU Room 20-21, 1st Floor, Building A, New Era Plaza, No 808 Gu Dun Road, Xi Hu District 0571-86560189</p>	<p>NANJING 1st Floor, Jin Sheng International Furniture Mall, No. 80 Middle Jiang Dong Road, Jian Ye District 025-84465566</p>	<p>SHANGHAI Room A8026-8029, 1st Floor, Red Star, No. 1388 Wu Zhong Road 021-64059508</p>	<p>WUHAN 1st Floor, No. 50 Xu Dong St, Wu Chang District 18627862789</p>	<p>CHENNAI 15, Khader Nawaz Khan Road, Nungambakkam +91 44 28333666 +91 9940149999</p>
<p>HANGZHOU Room B101-B201, No. 9 Pavilion, Metropolitan Furniture Expo Park, No. 1078 Jiang Nan Avenue 0571-87391806</p>	<p>NANJING No. 26, Middle Long Fan Road 025-85865566</p>	<p>SHENYANG Room J-1-007, 1st Floor, Red Star, No. 35 East Bei Er Road, Tie Xi District 024-85637679</p>	<p>WUXI 1st Floor, Easy Home, No. 18 East Jin Cheng Road 0510-88277796</p>	<p>AHMEDABAD Mondeal Business Park, House-W, Next To Gurudwara Temple, S.G. Highway +91 79 40095800 +91 9687629263</p>
<p>HANGZHOU Room B37, 2nd Floor, Sixth Space Art Life Square, No.18 Xi Hu Avenue 0571-87185539</p>	<p>NANTONG 2nd Floor, Internatioal Pavilion, Bai An Yi Jia Inetrnational Mall, No.288, Hao Xi Road, Gang Zha District 0513-89079988</p>	<p>SHENYANG Room A8002-8003, Red Star, No. 35 East Bei Er Road, Tie Xi District 024-31220872</p>	<p>WUXI Room A108, 1st Floor, Sixth Space Home Furnishing Square, No. 201 East Xi Hu Road 0510-82038116</p>	<p>KOLKATA 224, Krishna Building, A.J.C Bose Road, +91 33 30029890/91 +91 9830129000</p>
<p>HANGZHOU Room F128, 1st Floor, Sixth Space Xixi Living Art Plaze, No. 830 West Wen Yi Road 0571-87792898</p>	<p>NINGBO Room A-02, 1st Floor, Sixth Space Home Furnishing Square, No. 315 Ning Chuan Rd, Jiang Dong District 0574-87478192</p>	<p>SHENZHEN Room 1004a, 1004b, 1st Floor, Xing He Third Space, No. 3069 Cai Tian Road, Fu Tian District 0755-26941158</p>	<p>XIAMEN Room C8036, 3rd Floor, Red Star, No. 69 Zhong Zhai Road, Hu Li District 0592-5702230</p>	<p>MUMBAI 7, Raghuvanshi Mills Compound, Senapati Bapat Marg, Lower Parel (West) +91 22 24999098/99</p>
<p>HEFEI 1st Floor, Sixth Space, Yu Xi Road 0551-64631905</p>	<p>QINGDAO 1st Floor, Former International Home Furnishing Mall, No. 118 West Liao Yang Road 0532-80913397</p>	<p>SHENZHEN Room 1B021, 1st Floor, Red Star, Xiang Mi Hu Century Center, Fu Tian District 0755-83213913</p>	<p>XIAN 1st Floor, Easy Home, No. 4 Gao Xin Road, Gao Xin District 029-65653307</p>	<p>NEW DELHI 12/1 W.H.S Block A Kirti Nagar +91 11 41555015 +91 9910086595</p>
<p>HUHEHAOTE Room 2-1-001, Pavilion B, Building A, Easy Home, No. 169 North Xing An Road, Xin Cheng District 0471-2850680</p>	<p>SHANGHAI Room 101, Pavilion B6, JSWB, No. 5369 Jia Song Zhong Road, Qing Pu District 021-59755930</p>	<p>SUZHOU No. 57 Zhong Xin Road, Industrial Park 0512-67261500</p>	<p>XIANGYANG 1st Floor, Tian Li Furniture Mall, No. 9 Qian Jin Road 0710-3318799</p>	<p>PUNE 362 Building, Opposite Pune Central Bund Garden Road +91 20 26167171 /72</p>
<p>JINAN 1st Floor, Red Star, Bei Yuan St., Tian Qiao District 13589083266</p>	<p>SHANGHAI Room 405-406, 4th Floor, JSWB Furniture Center, No. 75 Lou Shan Guan Road 021-62369392</p>	<p>TAIYUAN 1st Floor, Easy Home, No.185 Chang Zhi Road 0351-7535918</p>	<p>ZHENGZHOU No. 1, North Gate, 1st Floor, Ou Kai Long Furnishing Mall, Intersection of Nong Ye Road and Shang Du Road 0371-55690099</p>	

INDONESIA

JAKARTA
Da Vinci Tower store: Jl. Jend.
Sudirman Kav, 12,
+6221 57952222

PAKISTAN

KARACHI
10-C Stadium Lane #1 off Kh-e-
Shamsheer Phase-V, D.H.A.
+221 35846328-35846055

SINGAPORE

SINGAPORE
100 Orchard Road
+65 64686333

SOUTH KOREA

BUNDANG
Daewaung Pangyo-Ro,
187 Bundang-gu, Seongnam-si,
b Gyeonggi-do
+82-31-786-0323

SEOUL

56-22, Nonhyun-Dong,
Kangnam-Ku
02-571-5854

SRI LANKA

COLOMBO
No 100, Galle Road,
+94 115517963
+94 115517964

TAIWAN

KAOHSIUNG
No.75, Bo Ai 3Rd Road.,
Zuoying Dist.,
+886 7 346 5678

TAICHUNG

No.1556, Sec. 1, Huanzhong Rd.,
Beitun District,
+886 4 2293 1668

TAIPEI

No. 89, Xinhu 2nd Rd.,
Neihu District, Taipei City 114
+886 2 8791 1318

TAIPEI

Room B2011, No.506, Sec. 1,
Zhongshan Rd.,
Xinzhuang City County 242
+886 2 8521-3838

THAILAND

BANGKOK
Siam Paragon
Department Store No. 336
0-2610-9692-4

VIETNAM

HCM CITY
327 Ha Noi highway,
An Phu Ward, Dist.2,
84-8 3744 2266

EUROPE**ARMENIA**

YEREVAN
Sebastia Str., 6
374 72 80 00

AZERBAIJAN

BAKU
Babek Prospekti 10 E.
+994 12 464 13 34

BOSNIA AND HERZEGOVINA

MOSTAR
Dubrovacka 63
00387 36312270

SARAJEVO

Dzemala Bijedica, 102
00387 33 719 210

CROATIA

ZAGREB
Cebini 39
38516658723

CYPRUS

NICOSIA
3 Acheon Street
22593901

CZECH REPUBLIC

BRNO
Prikop 4
420 545176231

BRNO

Svratecka 989
420 547213707

PRAGUE

Rubin Office Centre,
Pobrezni 50/52
420 296579410

PRAGUE

V Jame 3
420 224162056-7

FRANCE

ANNEMASSE
Ville la Grand
14 rue des Buchillons
04 50 79 94 83

CAEN

Mondeville
88 Rue de Paris
02 31 82 01 97

CLERMONT FERRAND

Lempdes
21 rue Henri Matisse
04 73 83 60 88

MONTPELLIER

Lattes Chemin de Soriech
04 67 65 53 80

NANTES

Orvault
290 Route de Vannes
02 40 59 59 60

PARIS

Rosny Sous Bois
16 rue de Lisbonne
Centre Commercial Domus
01 48 55 43 39

RENNES

Zone d'Activité de la Brosse
La Chapelle-des-Fougeretz
7 rue de la garenne
02 99 66 48 14

TOULOUSE

Portet-sur-Garonne
33 bis route d'Espagne
05 62 87 39 39

HUNGARY

TÖRÖKBÁLINT
Max City, 1. Emelet, Tópark U. 1/A
23 510 648

ITALY

LOCATE TRIULZI (MI)
Via Milano, 5
02 90731476

MILAN

Via Durini, 24
02 76319231"

ROME

Via Gregorio Vii, 314
06 6381486

KOSOVO

PRISHTINE
Lagjia Kalabria
(te kompleksi RIERA)
+37745980981

LATVIA

RIGA
K.Ulmana gatve 114/4
+371 67500107

MALTA

MALTA
Valley Road
+356 21446000

POLAND

KRAKOW
ul. Nowohucka 69A
12 656 39 00

WARSAW

CWW Domoteka
ul. Malborska 41
22/88-44-609

ROMANIA

BUCHAREST
Baneasa Park 42- 44,
Ploiesti Road Building A
0040 372 704 258

CLUJ - NAPOCA

Bucuresti Street 102 400613
Cluj-Napoca
0040 740 952 518
0040 786 881 583

RUSSIA

CHELYABINSK
Karla Marksa Str., 83
+7 351 266-18-57

IRKUTSK

Oktyabskoy Revolution Str., 1
+7 3952 258-259

MOSCOW

Frunzenskaya Embankment, 34
+7 495 798-28-98

NOVOSIBIRSK

Krylova Str., 31
+7 383 325-40-54

SAINT PETERSBURG

Moskovsky Avenue, 79
+7 812 601 06 16

SERBIA

BELGRADE
Tresnjinog cveta 11/12
381 11 2289-250

SLOVAKIA

BRATISLAVA
Landererova 8
+421 903 628 428

SLOVENIA

LJUBLJANA
Smartinska 53
00386 1 401 2010

SPAIN

ALCORCON
Centro Comercial Tres Aguas
Avda. De S. Martín
De Valdeiglesias, 24
91 621 00 16

BARCELONA

Avda Diagonal, 433 Bis
93 215 50 64

BILBAO

Calle Henao 56
944 231 978

MADRID

Avenida De Los Andes 12
91 393 08 34

MADRID

Calle Nuñez De Balboa, 81
91 431 88 32

MARBELLA

Parque Comercial La Canada,
Autovia Salida Ojen
952 77 07 07

PALMA DE MALLORCA

Calle Bonaire, 19
971 720 439

SAN SEBASTIAN DE LOS REYES

Parque Comercial
Megapark Ctra N I, Km 19
91 651 02 93

SAN SEBASTIAN

Avda Tolosa, 5
943 214 172

TENERIFE

Pol. Los Olivos Avenida Barranco
de las Torres, s/n esq. Atalaya, 7
822 25 79 20

VALENCIA

C/ Cirilo Amoros 51
96 351 54 22

ZARAGOZA

Shopping Center Puerto Venecia
Travesia de los Jardines Reales, 7
976 249 595.

SWITZERLAND

ETOY
Chemin Noyer Girod 8
021 808 81 60

ROTHRIST

Rössliweg 29
062 794 23 74

ZURICH

Talstrasse 9
043 497 21 10

TURKEY

ANKARA
Anse Avm B.Blok Zemin Kat No:9
Eskisehir Yolu, Mesa Koru KAVŞAĞI
0312 227 82 10

ISTANBUL

Cemil Topuzlu Caddesi No:16,
Selamicesme-Kadikoy
0216 3866303

ISTANBUL

Levent caddesi,
Alt Zeren Sokak,
no. 27, Levent
0212 2820006

UK

BIRMINGHAM
House of Fraser
Corporation Street
0121 212 9775

CARDIFF BAY

Havannah Street
0292 048 8698

CARDIFF

Cardiff Gate Retail Park
Dering Road
0292 073 3331

CROYDON

550A Purley Way
0208 401 0084

EDINBURGH

House of Fraser
48 Princes Street
0131 225 6309

GREENHITE

House of Fraser
Bluewater Shopping Centre
01322 423 808

GUILDFORD

House of Fraser
105-111 High Street
01483 306 280

HIGH WYCOMBE

House of Fraser
Eden Shopping Centre
01494 761 696

LONDON

Brent Cross Retail Park
Tilling Road
0208 450 4433

LONDON

333-339 Finchley Road
0203 813 5933

LONDON

80-81 Tottenham Court Road
0203 219 7840

LONDON

House Of Fraser
318 Oxford Street
0207 491 0760

LONDON

Lakeside Retail Park
West Thurrock
0170 825 2653

MAIDSTONE

South Aylesford Retail Park,
London Road Kent
44 01622 718871

MANCHESTER

Barton Square
Trafford Park
0845 867 8506

MANCHESTER

House Of Fraser
Deansgate
0161 839 6536

MILTON KEYNES

Winter Hill Retail Park
Snowdon Drive, Winterhill
01908 209 995

NORWICH

House of Fraser
130 Merchant Hall
01603 625 523

READING

House of Fraser
The Oracle
0118 956 6628

STEVENAGE

Roebuck Retail Park
01438 369 568

UKRAINE

KHARKOV
Lenina Ave, 7B
057 7192009

KIEV

Pr. of Victory, 3
+38 044 500-99-50

**MIDDLE EAST
EAST AFRICA****ALGERIA**

ALGER
125 Avenue Ahmed Ouaked,
Dely Brahim
+ 2130555 03 75 46

BAHRAIN

MANAMA
Palace Palms Bldg., Showroom 370
Seef District
+ 973 17564444

COTE D'IVOIRE

ABIDJAN
Boulevard Valéry
Giscard D'Estaing
+225 21 34 07 07
+225 06 73 70 09

EGYPT

CAIRO
Km 38 Cairo Alex Desert Road
00202 38571967

ISRAEL

BEER SHEVA
Derech Hevron 48
08-6420300

HAIFA

Kdoshei Iasi 2
04-8550567

HERTZELIA

Shenkar 5
09-9554000

JERUSALEM

Haoman 14
02-6799449

TEL AVIV

Ramat Gan
Ben-Gurion 2
5257334

JORDAN

JORDAN
Le Boulevard –
Rafic el Hariri Avenue,
Bldg West (L4)
+962 65102153
+962 796242111

LEBANON

BEIRUT
Foch Residence Bldg
Chafic Wazzan Avenue
Marfaa Down Town
+961 1 986987

LIBYA

LIBYA
Benashur Street
+218 91 339 3338

QATAR

DOHA
Al Rayyan Al Qadeem St,
AL Rayyan Park
+974 4021 2050

SAUDI ARABIA

JEDDAH
Tahlia Street,
Alhadab Tahlia Center
+96612-6608605

WKHOBAR

King Faysal Bin
Abdul Aziz Road,
+96613-8494433

RIYADH

Arcade center,
King Fahd road
+96611-4644230

UAE

ABU DHABI
Landmark Tower,
on Abu Dhabi Corniche
+971 2 6444048

DUBAI

Sheikh Zayed Road,
Between 2nd & 3rd
interchange
04-3380777

AUSTRALASIA**AUSTRALIA**

ALEXANDRIA NSW
504 Gardeners Rd
Cnr O'Riordan St
02 9669 1466

BLACKBURN VIC

220 Whitehorse Rd
03 9877 8154

CASTLE HILL NSW

Home Hub
Shop 30 North Building
18 Victoria Ave
02 8850 7401

KESWICK SA

21 Anzac Highway
08 8297 7000

NEWSTEAD QLD

37 Commercial Rd
07 3172 9184

OSBORNE PARK WA

Shop 11 Hometown
381 Scarborough Beach Rd
08 9444 8257

RICHMOND VIC

483 Church St
03 9428 3755

SUPA CENTA MOORE PARK NSW

Shop 26 Ground floor
2A Todman Ave
Cnr South Dowling St
Kensington
02 9662 6758

HQ**NATUZZI S.P.A.**

Via Iazzitiello, 47
Santeramo in Colle
Bari, Italy

+39 080 882 0111

natuzzi.com

CREDITS.

Creative Direction: **Pasquale Junior Natuzzi**

Graphic Design: **Natuzzi Creative Lab**

Photo: **Studio Target, Adamo Morgese, Giuseppe Manzi**

Copywriting: **Valeria Canavesi**

Styling: **Natuzzi Style Centre, Laura Comiotto**

Product illustrations and descriptions given in this catalogue are purely indicative. Natuzzi S.p.A. reserves the right to make aesthetic and/or functional modifications to all items without any prior warning and whenever such modifications are deemed necessary for commercial or manufacturing purposes.

© 2017 Natuzzi S.p.A. All rights reserved.

N

N

[natuzzi.com](https://www.natuzzi.com)